



Cisco Application Deployment Engine (ADE) 2130 and 2140 Series Appliance Hardware Installation Guide

April 2008

Americas Headquarters

Cisco Systems, Inc.
170 West Tasman Drive
San Jose, CA 95134-1706
USA
<http://www.cisco.com>
Tel: 408 526-4000
800 553-NETS (6387)
Fax: 408 527-0883

Text Part Number: 78-18579-02

THE SPECIFICATIONS AND INFORMATION REGARDING THE PRODUCTS IN THIS MANUAL ARE SUBJECT TO CHANGE WITHOUT NOTICE. ALL STATEMENTS, INFORMATION, AND RECOMMENDATIONS IN THIS MANUAL ARE BELIEVED TO BE ACCURATE BUT ARE PRESENTED WITHOUT WARRANTY OF ANY KIND, EXPRESS OR IMPLIED. USERS MUST TAKE FULL RESPONSIBILITY FOR THEIR APPLICATION OF ANY PRODUCTS.

THE SOFTWARE LICENSE AND LIMITED WARRANTY FOR THE ACCOMPANYING PRODUCT ARE SET FORTH IN THE INFORMATION PACKET THAT SHIPPED WITH THE PRODUCT AND ARE INCORPORATED HEREIN BY THIS REFERENCE. IF YOU ARE UNABLE TO LOCATE THE SOFTWARE LICENSE OR LIMITED WARRANTY, CONTACT YOUR CISCO REPRESENTATIVE FOR A COPY.

The following information is for FCC compliance of Class A devices: This equipment has been tested and found to comply with the limits for a Class A digital device, pursuant to part 15 of the FCC rules. These limits are designed to provide reasonable protection against harmful interference when the equipment is operated in a commercial environment. This equipment generates, uses, and can radiate radio-frequency energy and, if not installed and used in accordance with the instruction manual, may cause harmful interference to radio communications. Operation of this equipment in a residential area is likely to cause harmful interference, in which case users will be required to correct the interference at their own expense.

The following information is for FCC compliance of Class B devices: The equipment described in this manual generates and may radiate radio-frequency energy. If it is not installed in accordance with Cisco's installation instructions, it may cause interference with radio and television reception. This equipment has been tested and found to comply with the limits for a Class B digital device in accordance with the specifications in part 15 of the FCC rules. These specifications are designed to provide reasonable protection against such interference in a residential installation. However, there is no guarantee that interference will not occur in a particular installation.

Modifying the equipment without Cisco's written authorization may result in the equipment no longer complying with FCC requirements for Class A or Class B digital devices. In that event, your right to use the equipment may be limited by FCC regulations, and you may be required to correct any interference to radio or television communications at your own expense.

You can determine whether your equipment is causing interference by turning it off. If the interference stops, it was probably caused by the Cisco equipment or one of its peripheral devices. If the equipment causes interference to radio or television reception, try to correct the interference by using one or more of the following measures:

- Turn the television or radio antenna until the interference stops.
- Move the equipment to one side or the other of the television or radio.
- Move the equipment farther away from the television or radio.
- Plug the equipment into an outlet that is on a different circuit from the television or radio. (That is, make certain the equipment and the television or radio are on circuits controlled by different circuit breakers or fuses.)

Modifications to this product not authorized by Cisco Systems, Inc. could void the FCC approval and negate your authority to operate the product.

The Cisco implementation of TCP header compression is an adaptation of a program developed by the University of California, Berkeley (UCB) as part of UCB's public domain version of the UNIX operating system. All rights reserved. Copyright © 1981, Regents of the University of California.

NOTWITHSTANDING ANY OTHER WARRANTY HEREIN, ALL DOCUMENT FILES AND SOFTWARE OF THESE SUPPLIERS ARE PROVIDED "AS IS" WITH ALL FAULTS. CISCO AND THE ABOVE-NAMED SUPPLIERS DISCLAIM ALL WARRANTIES, EXPRESSED OR IMPLIED, INCLUDING, WITHOUT LIMITATION, THOSE OF MERCHANTABILITY, FITNESS FOR A PARTICULAR PURPOSE AND NONINFRINGEMENT OR ARISING FROM A COURSE OF DEALING, USAGE, OR TRADE PRACTICE.

IN NO EVENT SHALL CISCO OR ITS SUPPLIERS BE LIABLE FOR ANY INDIRECT, SPECIAL, CONSEQUENTIAL, OR INCIDENTAL DAMAGES, INCLUDING, WITHOUT LIMITATION, LOST PROFITS OR LOSS OR DAMAGE TO DATA ARISING OUT OF THE USE OR INABILITY TO USE THIS MANUAL, EVEN IF CISCO OR ITS SUPPLIERS HAVE BEEN ADVISED OF THE POSSIBILITY OF SUCH DAMAGES.

CCDE, CCENT, Cisco Eos, Cisco StadiumVision, the Cisco logo, DCE, and Welcome to the Human Network are trademarks; Changing the Way We Work, Live, Play, and Learn is a service mark; and Access Registrar, Aironet, AsyncOS, Bringing the Meeting To You, Catalyst, CCDA, CCDP, CCIE, CCIP, CCNA, CCNP, CCSP, CCVP, Cisco, the Cisco Certified Internetwork Expert logo, Cisco IOS, Cisco Press, Cisco Systems, Cisco Systems Capital, the Cisco Systems logo, Cisco Unity, Collaboration Without Limitation, Enterprise/Solver, EtherChannel, EtherFast, EtherSwitch, Event Center, Fast Step, Follow Me Browsing, FormShare, GigaDrive, HomeLink, Internet Quotient, IOS, iPhone, iQ Expertise, the iQ logo, iQ Net Readiness Scorecard, iQuick Study, IronPort, the IronPort logo, LightStream, Linksys, MediaTone, MeetingPlace, MGX, Networkers, Networking Academy, Network Registrar, PCNow, PIX, PowerPanels, ProConnect, ScriptShare, SenderBase, SMARTnet, Spectrum Expert, StackWise, The Fastest Way to Increase Your Internet Quotient, TransPath, WebEx, and the WebEx logo are registered trademarks of Cisco Systems, Inc. and/or its affiliates in the United States and certain other countries.

All other trademarks mentioned in this document or Website are the property of their respective owners. The use of the word partner does not imply a partnership relationship between Cisco and any other company. (0803R)

Cisco Application Deployment Engine (ADE) 2130 and 2140 Series Appliance Hardware Installation Guide
Copyright © 2008 Cisco Systems, Inc. All rights reserved.



CONTENTS

About This Guide **vii**

Document Revision History **viii**

Objectives **viii**

Audience **viii**

Organization **viii**

Conventions **ix**

Safety Warnings **x**

Related Documentation **xv**

Obtaining Documentation and Submitting a Service Request **xv**

CHAPTER 1

Introducing the Cisco Application Deployment Engine 2130 and 2140 Series Appliance **1-1**

Product Overview **1-2**

Product Serial Number Location **1-3**

Cisco Product Identification Tool **1-4**

Cisco ADE 2130 and 2140 Series Appliance Configurations **1-4**

Cisco ADE 2130 Series Appliance **1-4**

Cisco ADE 2140 Series Appliance **1-5**

Hardware Features **1-6**

Cisco ADE 2130 and 2140 Series Appliance Front View **1-6**

Front Control Panel LEDs and Switches **1-7**

Cisco ADE 2130 and 2140 Series Appliance Rear View **1-8**

NIC LEDs **1-9**

AC and DC Power Supply LEDs **1-10**

Input/Output Ports and Connectors **1-11**

Ethernet Port (NIC 1 and NIC 2) **1-11**

Serial (Console) Port **1-12**

AC and DC Power Supplies **1-15**

Environmental Monitoring **1-16**

Overcurrent Protection (OCP) **1-16**

Overvoltage Protection (OVP) **1-16**

Overtemperature Protection (OTP) **1-16**

Regulatory Compliance **1-16**

CHAPTER 2

Preparing to Install the Cisco ADE 2130 and 2140 Series Appliance 2-1

- Safety Guidelines 2-2
 - General Precautions 2-2
 - Safety with Equipment 2-3
 - Safety with Electricity 2-3
 - Preventing Electrostatic Discharge Damage 2-5
 - Lifting Guidelines 2-6
- Preparing Your Site for Installation 2-6
 - Site Planning 2-6
 - Rack Installation Safety Guidelines 2-7
 - Site Environment 2-8
 - Airflow Guidelines 2-9
 - Temperature and Humidity Guidelines 2-9
 - Power Considerations 2-10
 - Method of Procedure 2-11
 - Unpacking and Checking the Contents of Your Shipment 2-12
 - Cisco Information Packet and Warranty 2-13
 - Required Tools and Equipment 2-14
 - Installation Checklist 2-15
 - Creating a Site Log 2-15
- Ethernet and Console Port Considerations 2-16
 - NIC 1 and NIC 2 (RJ-45) Ethernet Connections 2-16
 - Serial (Console) Port Connections 2-16

CHAPTER 3

Installing the Cisco ADE 2130 and 2140 Series Appliance 3-1

- Rack-Mounting Configuration Guidelines 3-2
- Mounting the Cisco ADE 2130 and 2140 Series Appliance in a 2-Post Rack 3-3
 - 2-Post Rack-Mount Hardware Kit 3-4
 - Mid-Mounting in a 2-Post Rack 3-5
 - Attaching the L Brackets to the Appliance 3-5
 - Installing the Appliance in the Rack 3-6
- Mounting the Cisco ADE 2130 and 2140 Series Appliance in a 4-Post Rack 3-7
 - 4-Post Rack-Mount Hardware Kit 3-7
 - Attaching the Inner Slide Rails to the Appliance 3-8
 - Attaching the Outer Slide Rails to the Rack 3-9
 - Installing the Appliance into the Rack 3-9
- Cisco ADE 2130 and 2140 Series Appliance Power 3-11
 - Connecting the Appliance AC Power 3-12
 - Power Connections 3-13

Grounding the Rack	3-13
Connecting the Appliance DC Power and Ground	3-13
Grounding Connections	3-14
Power Connections	3-15
Wiring the DC-Input Power Source	3-16
Connecting the Network and Console Cables	3-18
Connecting the Network Interface	3-18
Connecting the Console	3-19
Cable Management	3-19
Powering Up the Cisco ADE 2130 and 2140 Series Appliance	3-20
Power-Up Procedure (AC Power Supply)	3-20
Power-Up Procedure (DC Power Supply)	3-21
Checking the LEDs	3-21
Removing or Replacing the Cisco ADE 2130 and 2140 Series Appliance	3-22

CHAPTER 4**Installing the Cisco ADE 2130 and 2140 Series Appliance Hardware Options 4-1**

Before You Begin	4-2
Preparing for a Successful Installation	4-2
Hardware Options	4-2
Tools and Supplies Needed	4-3
Beginning the Installation	4-3
Removing the Cover	4-3
Removing the Front Bezel	4-5
Installing a Hard Drive Tray into the Appliance	4-5
Removing and Installing the Processor Air Duct	4-7
Removing the Processor Air Duct	4-7
Installing the Processor Air Duct	4-9
Installing and Removing Memory	4-9
Installing DIMMs	4-11
Removing DIMMs	4-12
Removing and Installing the PCI Adapter Card	4-12
Removing the PCI Riser Assembly	4-14
Removing a PCI Adapter Card	4-15
Installing a PCI Adapter Card	4-16
Installing the PCI Riser Assembly	4-17
Installing or Replacing a Power Supply	4-17
Replacing a Redundant Power Supply	4-18
Replacing a Nonredundant Power Supply	4-19

Adding a New Redundant Power Supply 4-19
 Completing the Installation 4-20
 Installing the Cover 4-20

APPENDIX A

Troubleshooting A-1

Troubleshooting Overview A-1
 Problem Solving A-2
 Troubleshooting the Power and Cooling Systems A-3
 Environmental Reporting Features A-3
 Troubleshooting Adapter Cards, Cables, and Connections A-4
 Reading the LEDs A-5
 Front-Panel LEDs A-5
 NIC LEDs A-6
 Product Serial Number Location A-7
 Cisco Product Identification Tool A-7

APPENDIX B

Site Log B-1

APPENDIX C

Maintaining the Cisco ADE 2130 and 2140 Appliance C-1

Maintaining Your Site Environment C-1
 General Exterior Cleaning and Inspection C-2
 Appliance C-2
 Cables and Connectors C-2
 Adapter Cards C-2
 Cooling C-3
 Temperature C-3
 Humidity C-4
 Altitude C-4
 Electrostatic Discharge C-4
 Electromagnetic and Radio Frequency Interference C-4
 Magnetism C-5
 Power Source Interruptions C-5

INDEX



About This Guide

This preface describes who should read the *Cisco Application Deployment Engine (ADE) 2130 and 2140 Series Appliance Hardware Installation Guide*, and the objectives, audience, organization, and conventions for the guide.



Note

Use this document along with the documents listed in the [“Related Documentation”](#) section on page xv.

This preface contains the following sections:

- [Document Revision History, page viii](#)
- [Objectives, page viii](#)
- [Audience, page viii](#)
- [Organization, page viii](#)
- [Conventions, page ix](#)
- [Safety Warnings, page x](#)
- [Related Documentation, page xv](#)
- [Obtaining Documentation and Submitting a Service Request, page xv](#)

Document Revision History

The following Document Revision History table records technical changes to this document. The table shows the document revision number for the change, the date of the change, and a brief summary of the change.

Revision	Date	Change Summary
78-18579-02	April 2, 2008	Updated guide with correct banner photo, added Document Revision History, revised the “Attaching the Inner Slide Rails to the Appliance” section on page 3-8, revised Table 1-2 on page 5 , Table 1-3 on page 5 , Table 1-6 on page 10 , Table A-2 on page 7 , and fixed inconsistencies with some figures for on-line and PDF versions.
78-18579-01	February 22, 2007	Changed document to printed document from on-line document.
OL-14301-01	December 17, 2007	Initial release.

Objectives

This guide explains how to prepare your site for installation, how to install the Cisco ADE 2130 and 2140 Series appliance in an equipment rack, and how to troubleshoot and maintain the appliance. After completing the appliance installation procedures covered in this guide, you then use the appropriate publications to configure your appliance.

Warranty, service, and support information is located in the *Cisco Information Packet* that shipped with your appliance.

Audience

This guide is designed for personnel who install, configure, and maintain the Cisco ADE 2130 and 2140 Series appliance. To use this hardware publication, you should be familiar with internetworking equipment and cabling, and have a basic knowledge of electronic circuitry and wiring practices.



Warning

Only trained and qualified personnel should be allowed to install, replace, or service this equipment.
Statement 1030

Organization

The major sections of this hardware installation guide are listed in the following table.

Chapter	Title	Description
Chapter 1	Introducing the Cisco Application Deployment Engine 2130 and 2140 Series Appliance	Describes the hardware features and specifications of the Cisco ADE 2130 and 2140 Series appliance.
Chapter 2	Preparing to Install the Cisco ADE 2130 and 2140 Series Appliance	Describes the safety recommendations, site requirements, network connection considerations, required tools and equipment, and provides an installation checklist.
Chapter 3	Installing the Cisco ADE 2130 and 2140 Series Appliance	Includes appliance installation information, including how to connect the appliance console and network ports.
Chapter 4	Installing the Cisco ADE 2130 and 2140 Series Appliance Hardware Options	Describes how to install and remove the hardware options available, including DIMM memory, hard disk drives, and the optical drive.
Appendix A	Troubleshooting	Describes troubleshooting procedures for the appliance.
Appendix B	Site Log	Provides a sample site log.
Appendix C	Maintaining the Cisco ADE 2130 and 2140 Appliance	Contains the procedures for keeping your appliance in good condition.

Conventions

This guide uses the following conventions to convey instructions and information.



Note

Means *reader take note*. Notes contain helpful suggestions or references to material not covered in the manual.



Timesaver

Means *the described action saves time*. You can save time by performing the action described in the paragraph.



Tip

Means *the following information will help you solve a problem*. The tips information might not be troubleshooting or even an action, but could be useful information, similar to a Timesaver.



Caution

Means *reader be careful*. In this situation, you might do something that could result in equipment damage or loss of data.

Safety Warnings

Safety warnings appear throughout this publication in procedures that, if performed incorrectly, might harm you. A warning symbol precedes each warning statement. The safety warnings provide safety guidelines that you should follow when working with any equipment that connects to electrical power or telephone wiring. Included in the warnings are translations in several languages. (Refer to the *Cisco Regulatory Compliance and Safety Information for the Cisco Application Deployment Engine (ADE) 2130 and 2140 Series Appliance* for detailed information about compliance guidelines and translated safety warnings.)



Warning

IMPORTANT SAFETY INSTRUCTIONS

This warning symbol means danger. You are in a situation that could cause bodily injury. Before you work on any equipment, be aware of the hazards involved with electrical circuitry and be familiar with standard practices for preventing accidents. Use the statement number provided at the end of each warning to locate its translation in the translated safety warnings that accompanied this device. Statement 1071

SAVE THESE INSTRUCTIONS

Waarschuwing

BELANGRIJKE VEILIGHEIDSINSTRUCTIES

Dit waarschuwingssymbool betekent gevaar. U verkeert in een situatie die lichamelijk letsel kan veroorzaken. Voordat u aan enige apparatuur gaat werken, dient u zich bewust te zijn van de bij elektrische schakelingen betrokken risico's en dient u op de hoogte te zijn van de standaard praktijken om ongelukken te voorkomen. Gebruik het nummer van de verklaring onderaan de waarschuwing als u een vertaling van de waarschuwing die bij het apparaat wordt geleverd, wilt raadplegen.

BEWAAR DEZE INSTRUCTIES

Varoitus

TÄRKEITÄ TURVALLISUUSOHJEITA

Tämä varoitusmerkki merkitsee vaaraa. Tilanne voi aiheuttaa ruumiillisia vammoja. Ennen kuin käsittelet laitteistoa, huomioi sähköpiirien käsittelemiseen liittyvät riskit ja tutustu onnettomuuksien yleisiin ehkäisytapoihin. Turvallisuusvaroitusten käännökset löytyvät laitteen mukana toimitettujen käännettyjen turvallisuusvaroitusten joukosta varoitusten lopussa näkyvien lausuntonumeroiden avulla.

SÄILYTÄ NÄMÄ OHJEET

Attention

IMPORTANTES INFORMATIONS DE SÉCURITÉ

Ce symbole d'avertissement indique un danger. Vous vous trouvez dans une situation pouvant entraîner des blessures ou des dommages corporels. Avant de travailler sur un équipement, soyez conscient des dangers liés aux circuits électriques et familiarisez-vous avec les procédures couramment utilisées pour éviter les accidents. Pour prendre connaissance des traductions des avertissements figurant dans les consignes de sécurité traduites qui accompagnent cet appareil, référez-vous au numéro de l'instruction situé à la fin de chaque avertissement.

CONSERVEZ CES INFORMATIONS

Warnung WICHTIGE SICHERHEITSHINWEISE

Dieses Warnsymbol bedeutet Gefahr. Sie befinden sich in einer Situation, die zu Verletzungen führen kann. Machen Sie sich vor der Arbeit mit Geräten mit den Gefahren elektrischer Schaltungen und den üblichen Verfahren zur Vorbeugung vor Unfällen vertraut. Suchen Sie mit der am Ende jeder Warnung angegebenen Anweisungsnummer nach der jeweiligen Übersetzung in den übersetzten Sicherheitshinweisen, die zusammen mit diesem Gerät ausgeliefert wurden.

BEWAHREN SIE DIESE HINWEISE GUT AUF.

Avvertenza IMPORTANTI ISTRUZIONI SULLA SICUREZZA

Questo simbolo di avvertenza indica un pericolo. La situazione potrebbe causare infortuni alle persone. Prima di intervenire su qualsiasi apparecchiatura, occorre essere al corrente dei pericoli relativi ai circuiti elettrici e conoscere le procedure standard per la prevenzione di incidenti. Utilizzare il numero di istruzione presente alla fine di ciascuna avvertenza per individuare le traduzioni delle avvertenze riportate in questo documento.

CONSERVARE QUESTE ISTRUZIONI

Advarsel VIKTIGE SIKKERHETSINSTRUKSJONER

Dette advarselssymbolet betyr fare. Du er i en situasjon som kan føre til skade på person. Før du begynner å arbeide med noe av utstyret, må du være oppmerksom på farene forbundet med elektriske kretser, og kjenne til standardprosedyrer for å forhindre ulykker. Bruk nummeret i slutten av hver advarsel for å finne oversettelsen i de oversatte sikkerhetsadvarslene som fulgte med denne enheten.

TA VARE PÅ DISSE INSTRUKSJONENE

Aviso INSTRUÇÕES IMPORTANTES DE SEGURANÇA

Este símbolo de aviso significa perigo. Você está em uma situação que poderá ser causadora de lesões corporais. Antes de iniciar a utilização de qualquer equipamento, tenha conhecimento dos perigos envolvidos no manuseio de circuitos elétricos e familiarize-se com as práticas habituais de prevenção de acidentes. Utilize o número da instrução fornecido ao final de cada aviso para localizar sua tradução nos avisos de segurança traduzidos que acompanham este dispositivo.

GUARDE ESTAS INSTRUÇÕES

¡Advertencia! INSTRUCCIONES IMPORTANTES DE SEGURIDAD

Este símbolo de aviso indica peligro. Existe riesgo para su integridad física. Antes de manipular cualquier equipo, considere los riesgos de la corriente eléctrica y familiarícese con los procedimientos estándar de prevención de accidentes. Al final de cada advertencia encontrará el número que le ayudará a encontrar el texto traducido en el apartado de traducciones que acompaña a este dispositivo.

GUARDE ESTAS INSTRUCCIONES

Varning! VIKTIGA SÄKERHETSANVISNINGAR

Denna varningssignal signalerar fara. Du befinner dig i en situation som kan leda till personskada. Innan du utför arbete på någon utrustning måste du vara medveten om farorna med elkretsar och känna till vanliga förfaranden för att förebygga olyckor. Använd det nummer som finns i slutet av varje varning för att hitta dess översättning i de översatta säkerhetsvarningar som medföljer denna anordning.

SPARA DESSA ANVISNINGAR**Figyelem FONTOS BIZTONSÁGI ELOÍRÁSOK**

Ez a figyelmeztető jel veszélyre utal. Sérülésveszélyt rejtő helyzetben van. Mielőtt bármely berendezésen munkát végezte, legyen figyelemmel az elektromos áramkörök okozta kockázatokra, és ismerkedjen meg a szokásos balesetvédelmi eljárásokkal. A kiadványban szereplő figyelmeztetések fordítása a készülékhez mellékelt biztonsági figyelmeztetések között található; a fordítás az egyes figyelmeztetések végén látható szám alapján kereshető meg.

ORIZZE MEG EZEKET AZ UTASÍTÁSOKAT!**Предупреждение ВАЖНЫЕ ИНСТРУКЦИИ ПО СОБЛЮДЕНИЮ ТЕХНИКИ БЕЗОПАСНОСТИ**

Этот символ предупреждения обозначает опасность. То есть имеет место ситуация, в которой следует опасаться телесных повреждений. Перед эксплуатацией оборудования выясните, каким опасностям может подвергаться пользователь при использовании электрических цепей, и ознакомьтесь с правилами техники безопасности для предотвращения возможных несчастных случаев. Воспользуйтесь номером заявления, приведенным в конце каждого предупреждения, чтобы найти его переведенный вариант в переводе предупреждений по безопасности, прилагаемом к данному устройству.

СОХРАНИТЕ ЭТИ ИНСТРУКЦИИ**警告 重要的安全性说明**

此警告符号代表危险。您正处于可能受到严重伤害的工作环境中。在您使用设备开始工作之前，必须充分意识到触电的危险，并熟练掌握防止事故发生的标准工作程序。请根据每项警告结尾提供的声明号码来找到此设备的安全性警告说明的翻译文本。

请保存这些安全性说明

警告 安全上の重要な注意事項

「危険」の意味です。人身事故を予防するための注意事項が記述されています。装置の取り扱い作業を行うときは、電気回路の危険性に注意し、一般的な事故防止策に留意してください。警告の各国語版は、各注意事項の番号を基に、装置に付属の「Translated Safety Warnings」を参照してください。

これらの注意事項を保管しておいてください。

주의 **중요 안전 지침**

이 경고 기호는 위험을 나타냅니다. 작업자가 신체 부상을 일으킬 수 있는 위험한 환경에 있습니다. 장비에 작업을 수행하기 전에 전기 회로와 관련된 위험을 숙지하고 표준 작업 관례를 숙지하여 사고를 방지하십시오. 각 경고의 마지막 부분에 있는 경고문 번호를 참조하여 이 장치와 함께 제공되는 번역된 안전 경고문에서 해당 번역문을 찾으십시오.

이 지시 사항을 보관하십시오.

Aviso **INSTRUÇÕES IMPORTANTES DE SEGURANÇA**

Este símbolo de aviso significa perigo. Você se encontra em uma situação em que há risco de lesões corporais. Antes de trabalhar com qualquer equipamento, esteja ciente dos riscos que envolvem os circuitos elétricos e familiarize-se com as práticas padrão de prevenção de acidentes. Use o número da declaração fornecido ao final de cada aviso para localizar sua tradução nos avisos de segurança traduzidos que acompanham o dispositivo.

GUARDE ESTAS INSTRUÇÕES**Advarsel** **VIGTIGE SIKKERHEDSANVISNINGER**

Dette advarselssymbol betyder fare. Du befinder dig i en situation med risiko for legemeskadedigelse. Før du begynder arbejde på udstyr, skal du være opmærksom på de involverede risici, der er ved elektriske kredsløb, og du skal sætte dig ind i standardprocedurer til undgåelse af ulykker. Brug erklæringsnummeret efter hver advarsel for at finde oversættelsen i de oversatte advarsler, der fulgte med denne enhed.

GEM DISSE ANVISNINGER**تحذير****إرشادات الأمان الهامة**

يوضح رمز التحذير هذا وجود خطر. وهذا يعني أنك متواجد في مكان قد ينتج عنه التعرض للإصابات. قبل بدء العمل، احذر مخاطر التعرض للصدمات الكهربائية وكن على علم بالإجراءات القياسية للحيولة دون وقوع أي حوادث. استخدم رقم البيان الموجود في آخر كل تحذير لتحديد مكان ترجمته داخل تحذيرات الأمان المترجمة التي تأتي مع الجهاز. قم بحفظ هذه الإرشادات

Upozorenje **VAŽNE SIGURNOSNE NAPOMENE**

Ovaj simbol upozorenja predstavlja opasnost. Nalazite se u situaciji koja može prouzročiti tjelesne ozljede. Prije rada s bilo kojim uređajem, morate razumjeti opasnosti vezane uz električne sklopove, te biti upoznati sa standardnim načinima izbjegavanja nesreća. U prevedenim sigurnosnim upozorenjima, priloženima uz uređaj, možete prema broju koji se nalazi uz pojedino upozorenje pronaći i njegov prijevod.

SAČUVAJTE OVE UPUTE

Upozornění DŮLEŽITÉ BEZPEČNOSTNÍ POKYNY

Tento upozorňující symbol označuje nebezpečí. Jste v situaci, která by mohla způsobit nebezpečí úrazu. Před prací na jakémkoliv vybavení si uvědomte nebezpečí související s elektrickými obvody a seznamte se se standardními opatřeními pro předcházení úrazům. Podle čísla na konci každého upozornění vyhledejte jeho překlad v přeložených bezpečnostních upozorněních, která jsou přiložena k zařízení.

USCHOVEJTE TYTO POKYNY**Προειδοποίηση ΣΗΜΑΝΤΙΚΕΣ ΟΔΗΓΙΕΣ ΑΣΦΑΛΕΙΑΣ**

Αυτό το προειδοποιητικό σύμβολο σημαίνει κίνδυνο. Βρίσκεστε σε κατάσταση που μπορεί να προκαλέσει τραυματισμό. Πριν εργαστείτε σε οποιοδήποτε εξοπλισμό, να έχετε υπόψη σας τους κινδύνους που σχετίζονται με τα ηλεκτρικά κυκλώματα και να έχετε εξοικειωθεί με τις συνήθειες πρακτικές για την αποφυγή ατυχημάτων. Χρησιμοποιήστε τον αριθμό δήλωσης που παρέχεται στο τέλος κάθε προειδοποίησης, για να εντοπίσετε τη μετάφρασή της στις μεταφρασμένες προειδοποιήσεις ασφαλείας που συνοδεύουν τη συσκευή.

ΦΥΛΑΞΤΕ ΑΥΤΕΣ ΤΙΣ ΟΔΗΓΙΕΣ**אזהרה****הוראות בטיחות חשובות**

סימן אזהרה זה מסמל סכנה. אתה נמצא במצב העלול לגרום לפציעה. לפני שתעבוד עם ציוד כלשהו, עליך להיות מודע לסכנות הכרוכות במעגלים חשמליים ולהכיר את הנהלים המקובלים למניעת תאונות. השתמש במספר ההוראה המסופק בסופה של כל אזהרה כדי לאתר את התרגום באזהרות הבטיחות המתורגמות שמצורפות להתקן.

שמור הוראות אלה**Opomena VAŽNI BEZBEDNOSNI NAPATSTVIJA**

Симболот за предупредување значи опасност. Се наоѓате во ситуација што може да предизвика телесни повреди. Пред да работите со опремата, бидете свесни за ризикот што постои кај електричните кола и треба да ги познавате стандардните постапки за спречување на несреќни случаи. Искористете го бројот на изјавата што се наоѓа на крајот на секое предупредување за да го најдете неговиот период во преведените безбедносни предупредувања што се испорачани со уредот.

ЧУВАЈТЕ ГИ ОВИЕ НАПАТСТВИЈА

Ostrzeżenie WAŻNE INSTRUKCJE DOTYCZĄCE BEZPIECZEŃSTWA

Ten symbol ostrzeżenia oznacza niebezpieczeństwo. Zachodzi sytuacja, która może powodować obrażenia ciała. Przed przystąpieniem do prac przy urządzeniach należy zapoznać się z zagrożeniami związanymi z układami elektrycznymi oraz ze standardowymi środkami zapobiegania wypadkom. Na końcu każdego ostrzeżenia podano numer, na podstawie którego można odszukać tłumaczenie tego ostrzeżenia w dołączonym do urządzenia dokumencie z tłumaczeniami ostrzeżeń.

NINIEJSZE INSTRUKCJE NALEŻY ZACHOWAĆ**Upozornenie DÔLEŽITÉ BEZPEČNOSTNÉ POKYNY**

Tento varovný symbol označuje nebezpečenstvo. Nachádzate sa v situácii s nebezpečenstvom úrazu. Pred prácou na akomkoľvek vybavení si uvedomte nebezpečenstvo súvisiace s elektrickými obvodmi a oboznámte sa so štandardnými opatreniami na predchádzanie úrazom. Podľa čísla na konci každého upozornenia vyhľadajte jeho preklad v preložených bezpečnostných upozorneniach, ktoré sú priložené k zariadeniu.

USCHOVAJTE SI TENTO NÁVOD

Related Documentation

For information beyond the scope of this document, or for additional information about the Cisco ADE 2130 and 2140 Series appliance, refer to the following publications:

- *Cisco Regulatory Compliance and Safety Information for the Cisco Application Deployment Engine (ADE) 2130 and 2140 Series Appliance*
- *Cisco Application Deployment Engine Appliance (ADE) 2130 and 2140 Series Appliance Release Notes*

Obtaining Documentation and Submitting a Service Request

For information on obtaining documentation, submitting a service request, and gathering additional information, see the monthly *What's New in Cisco Product Documentation*, which also lists all new and revised Cisco technical documentation, at:

<http://www.cisco.com/en/US/docs/general/whatsnew/whatsnew.html>

Subscribe to the *What's New in Cisco Product Documentation* as a Really Simple Syndication (RSS) feed and set content to be delivered directly to your desktop using a reader application. The RSS feeds are a free service and Cisco currently supports RSS version 2.0.





CHAPTER 1

Introducing the Cisco Application Deployment Engine 2130 and 2140 Series Appliance

This chapter provides a functional overview of the Cisco Application Deployment Engine (ADE) 2130 and 2140 Series appliance and describes the appliance hardware, major components, and front- and rear-panel LED indicators, controls, and connectors.

This chapter includes the following sections:

- [Product Overview, page 1-2](#)
- [Hardware Features, page 1-6](#)
- [Environmental Monitoring, page 1-16](#)
- [Regulatory Compliance, page 1-16](#)

Product Overview

The Cisco ADE 2130 and 2140 Series appliance (see [Figure 1-1](#)) is contained in a standard shelf-rack enclosure. The appliance weighs from 30 lb (13.6 kg) to 51.5 lb (23.4 kg) depending on what options are installed in the appliance. It measures 3.5 inches high x 16.93 inches wide x 20 inches deep (8.9 cm x 43.2 cm x 50.8 cm). These dimensions do not include the rack handles.

Figure 1-1 Cisco ADE 2130 and 2140 Series Appliance

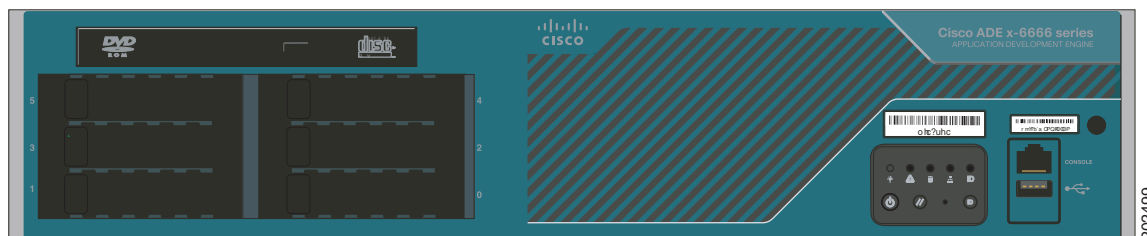

This guide describes the Cisco ADE 2130 and 2140 Series appliance models listed in [Table 1-1](#).

Table 1-1 Cisco ADE 2130 and 2140 Series Appliance Models

Model	Cisco Product Number
Cisco Application Deployment Engine Series 2130	CADE-2130-K9
Cisco Application Deployment Engine Series 2140	CADE-2140-K9



Note

See [Chapter 4, “Installing the Cisco ADE 2130 and 2140 Series Appliance Hardware Options,”](#) for upgrade options and spare part numbers.

The Cisco ADE 2130 and 2140 Series appliance is configured for AC-input or DC-input power, mounted in a standard 19-inch (48.3 cm) 2- or 4-post equipment rack (using the rack-mount brackets provided), and includes the following features:

- Microprocessor:
 - Cisco ADE 2130 Series appliance—Intel Xeon 1.86-GHz processor with a 1066-MHz front side bus (FSB) and 8 MB of Layer 2 cache (for the Cisco ADE 2130 Series appliance specifications, see [Table 1-2 on page 1-5](#))
 - Cisco ADE 2140 Series appliance—Dual Intel Xeon 1.86-GHz processor with a 1066-MHz front side bus (FSB) and 8 MB of Layer 2 cache (for the Cisco ADE 2140 Series appliance specifications, see [Table 1-3 on page 1-5](#))
- Eight synchronous dynamic RAM (SDRAM) slots support up to 8 GB (2 GB factory installed)
- Support for up to 6 x 147-GB SAS hard drives (1 x 147-GB SAS hard drive factory installed)
- Integrated RAID at levels 0, 1, 5, 1+0, and 5+0
- Two fixed RJ-45 10BASE-T/100BASE-TX/1000BASE-T network interface connectors (located on the rear panel)
- Two optional RJ-45 10BASE-T/100BASE-TX/1000BASE-T network interface connectors using a mezzanine module (located on the rear panel)

- One optional DVD-ROM drive (located on the front panel)
- Two RJ-45 serial (console) ports (one located on the front panel and one located on the rear panel)
- Single or redundant (optional) AC or DC power supply
- Front-to-rear airflow blowers using two 40 x 40 x 56-mm exhaust fans and ducting for the CPU and memory, and two 40-mm exhaust fans built in to the power supply
- Expansion slot support (located on the rear panel):
 - Two PCIe, low profile
 - Three PCI-X full height
- Three USB 2.0 ports (one located on the front panel, USB 2; two located on the rear panel, USB 0 and USB 1)
- One PS/2 (keyboard) port (located on the rear panel)¹
- One PS/2 (mouse) port (located on the rear panel)¹
- One DB-15 serial (video) port (located on the rear panel)
- Rear access cabling
- Five front-panel appliance LEDs (for a description, see the “[Cisco ADE 2130 and 2140 Series Appliance Front View](#)” section on page 1-6):
 - NIC activity (indicates whether interrupts or packet transfers are running)
 - Power (indicates whether the power supply is operational)
 - Hard disk drive activity (indicates whether the drive is functioning properly)
 - Appliance status
 - Appliance identification
- The Cisco ADE 2130 and 2140 Series appliance is normally shipped with:
 - Rack-mount kit including either brackets or rails allowing the Cisco ADE 2130 and 2140 Series appliance to be positioned in a 2- or 4-post equipment rack. (See [Chapter 3, “Installing the Cisco ADE 2130 and 2140 Series Appliance.”](#))

Product Serial Number Location

On the Cisco ADE 2130 and 2140 Series appliance, the serial number label is located on the right-hand corner above the RJ-45 serial (console) connector on the front of the appliance. (See [Figure 1-2 on page 1-4.](#))

1. Either PS/2 port can support the mouse or keyboard. Neither port supports hot-plugging.

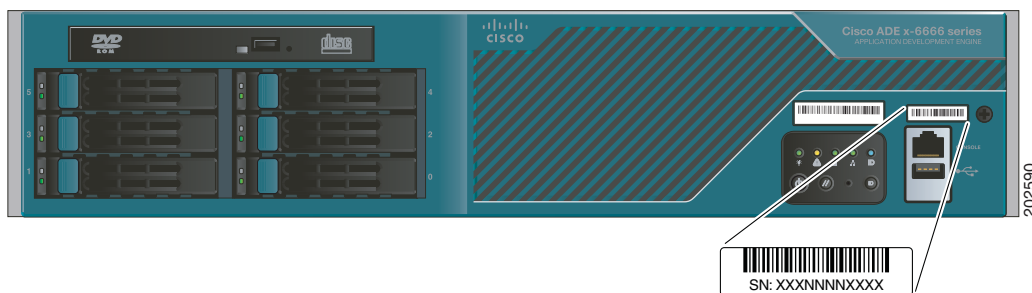
Figure 1-2 Cisco ADE 2130 and 2140 Series Appliance Serial Number Location**Note**

The serial number for the Cisco ADE 2130 and 2140 Series appliance is 11 characters long.

Cisco Product Identification Tool

The Cisco Product Identification (CPI) tool helps you retrieve the serial number of the Cisco products.

Before you submit a request for service online or by phone, use the CPI tool to locate the product serial number. You can access this tool from the Cisco Support website by clicking the **Get Tools & Resources** link, clicking the **All Tools (A-Z)** tab, and then choosing **Cisco Product Identification Tool** from the alphabetical list.

This tool offers three search options:

- Search by product ID or model name
- Browse for Cisco model
- Copy and paste the output of the **show** command to identify the product

Search results show an illustration of the product with the serial number label location highlighted. Locate the serial number label on the product and record the information before you place a service call.

The CPI tool is accessed via Cisco.com at the following URL:

<http://tools.cisco.com/Support/CPI/index.do>

Access to the CPI tool on the Cisco Support website requires a Cisco.com user ID and password. If you have a valid service contract but do not have a user ID or password, you can register at:

<http://tools.cisco.com/RPF/register/register.do>

Cisco ADE 2130 and 2140 Series Appliance Configurations

The Cisco ADE 2130 and 2140 Series appliance models are configured differently.

Cisco ADE 2130 Series Appliance

The Cisco ADE 2130 Series appliance is a base-end Application Deployment Engine. [Table 1-2 on page 1-5](#) lists the processor, memory, hard disk drive, and expansion slot specifications.

Table 1-2 Cisco ADE 2130 Series Appliance

Specification	Description	Cisco Spare Part Number ¹
Microprocessor	Intel Xeon 1.86-GHz processor with a 1066-MHz front side bus (FSB) and 8 MB of Layer 2 cache	
Memory	2-GB SDRAM	CADE-RAM-25EF=
Hard disk drives	1 x 147-GB SAS hard drive factory installed	CADE-HDD-A2100147=
Power supply	AC power supply	CADE-2U-AC-PSU=
	DC power supply	CADE-2U-DC-PSU=
Adapter card (expansion) slot	Three PCI-X and two x4 PCIe	
RAID Options	Hardware RAID 0, 1, 5, or 1+0 via integrated Intel RAID controller Battery-backed write cache—configurable to 512 MB	

1. See [Chapter 4, “Installing the Cisco ADE 2130 and 2140 Series Appliance Hardware Options,”](#) for hardware option descriptions and installation and removal procedures.

Cisco ADE 2140 Series Appliance

The Cisco ADE 2140 Series appliance is the same as the Cisco ADE 2130 Series appliance but with a faster processor. [Table 1-3](#) lists the processor, memory, hard disk drive, and expansion slot specifications.

Table 1-3 Cisco ADE 2140 Series Appliance

Specification	Description	Cisco Spare Part Number ¹
Microprocessor	Dual Intel Xeon 1.86-GHz processor with a 1066-MHz front side bus (FSB) and 8 MB of Layer 2 cache	
Memory	2-GB SDRAM	CADE-RAM-25EF=
Hard disk drives	1 x 147-GB SAS hard drive factory installed	CADE-HDD-A2100147=
Power supply	AC power supply	CADE-2U-AC-PSU=
	DC power supply	CADE-2U-DC-PSU=
Adapter card (expansion) slot	Three PCI-X and two x4 PCIe	
RAID Options	Hardware RAID 0, 1, 5, or 1+0 via integrated Intel RAID controller Battery-backed write cache—configurable to 512 MB	

1. See [Chapter 4, “Installing the Cisco ADE 2130 and 2140 Series Appliance Hardware Options,”](#) for hardware option descriptions and installation and removal procedures.

Hardware Features

This section illustrates and describes the front- and rear-panel controls, ports, and LED indicators on the Cisco ADE 2130 and 2140 Series appliance.

Cisco ADE 2130 and 2140 Series Appliance Front View

On the front panel, viewing from left to right, the Cisco ADE 2130 and 2140 Series appliance includes the following components:

- DVD drive
- Hard drives
- Hard drive LEDs
- Control switches and status LEDs
- Video connector
- RJ-45 serial (console) port
- USB 2.0 port

Figure 1-3 shows the orientation of these components.

Figure 1-3 Cisco ADE 2130 and 2140 Series Appliance Front View

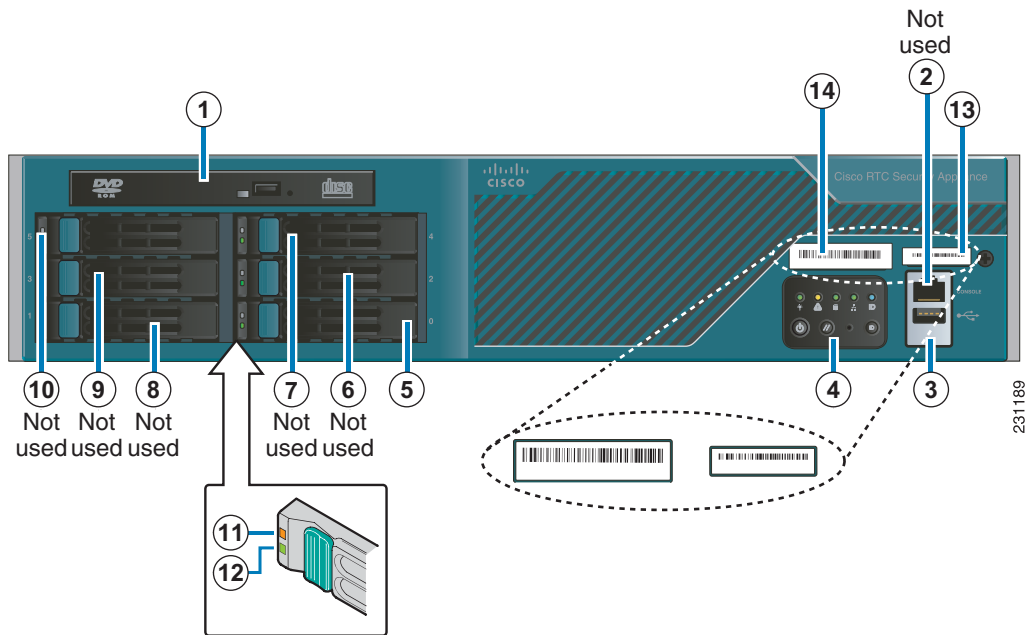

1	DVD drive (optional) or filler panel (if no drive is installed)	8	Hard drive 1
2	RJ-45 serial port	9	Hard drive 3
3	USB 2 port	10	Hard drive 5

4	Control switches and status LEDs (see Figure 1-4)	11	Hard drive fault LED (one per drive)
5	Hard drive 0	12	Hard drive activity LED (one per drive)
6	Hard drive 2	13	Serial number of ADE 1010/2120
7	Hard drive 4	14	Product ID (PID) of ADE 1010/2120

Front Control Panel LEDs and Switches

[Figure 1-4](#) shows the location of the Cisco ADE 2130 and 2140 Series appliance LEDs and switches on the front panel. [Table 1-4](#) describes the LEDs located on the front panel. [Table 1-5 on page 1-8](#) describes the switches located on the front panel.

Figure 1-4 Cisco ADE 2130 and 2140 Series Appliance Front Control Panel

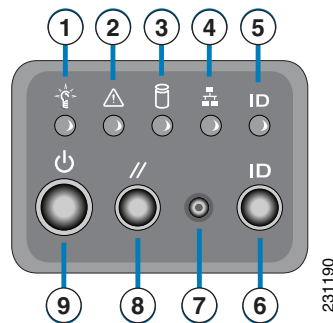

Table 1-4 Front Control Panel LEDs

LED	Color	State	Description
Appliance Power (location 1)	Green	On	Power on
	Off	Off	Power off
Appliance Status (location 2)	Green	On	Standby or ready for operation
	Green	Blinking	Degraded operation (for example, power supply nonredundancy, part of system memory mapped out of BIOS)
	Amber	On	One or more critical fault conditions
	Amber	Blinking	One or more noncritical fault conditions
Hard Disk Drive (location 3)	Green	On	HDD activity
	Amber	On	HDD fault
			Note This is an aggregated indication for all hard disk drives. Each hard disk drive contains its own activity and fault LEDs.

Table 1-4 Front Control Panel LEDs

LED	Color	State	Description
NICs (location 4)	Green	On	NIC activity
System ID (location 5)	Blue		System identity Note LED can be toggled remotely or by the front-panel ID switch to obtain the system's identity.

Table 1-5 Front Control Panel Switches

Switch	Description
ID (location 6)	Toggles appliance ID LED
NMI (location 7)	Asserts the NMI ¹ (non-maskable interrupt) to the processor on the appliance
Reset (location 8)	Resets the appliance
Power (location 9)	Toggles the appliance power

1. When pressed, clears the processor allowing the processor to continue to execute the software normally.

Cisco ADE 2130 and 2140 Series Appliance Rear View

On the rear panel, viewing from left to right, the Cisco ADE 2130 and 2140 Series appliance includes the following components:

- Two PS/2 connectors (mouse and keyboard)
- One RJ-45 serial (console) connector
- Two RJ-45 NIC (1 and 2) ports
- One video (VGA) port
- Two USB 2.0 ports
- Five PCI adapter card slots (expansion slots)
- (Optional) Two RJ-45 NIC (3 and 4) ports



Note If the optional NIC ports (3 and 4) using a mezzanine module are not installed, a filler panel occupies this space.

- AC power connector or DC power connector

Figure 1-5 shows the orientation of the following components.



Note

The locations of the rack-mounting brackets are also shown on the left and right sides of the appliance. (See the “[Rack-Mounting Configuration Guidelines](#)” section on page 3-2 for instructions on how to install the mounting brackets.)

Figure 1-5 Cisco ADE 2130 and 2140 Series Appliance Rear View

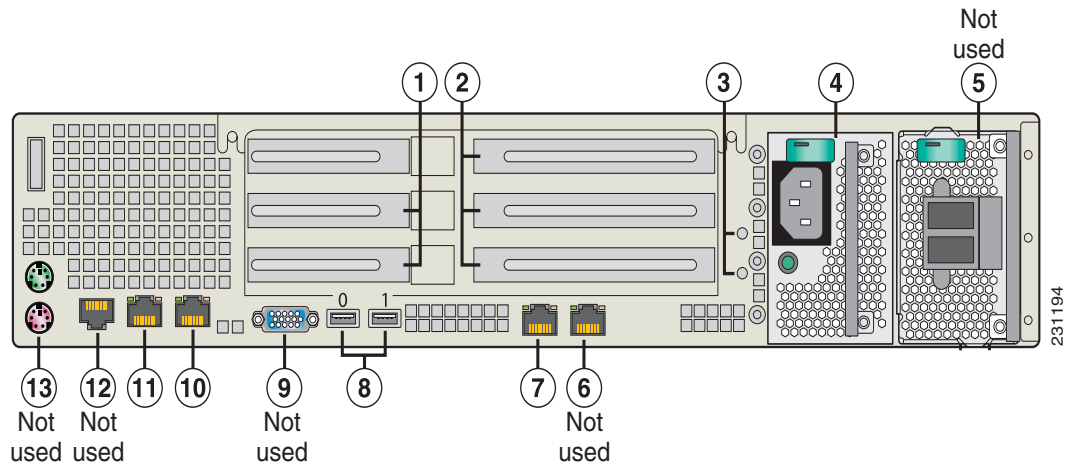

1	Two low-profile PCI Express adapter card slots	8	Two USB ports (0 and 1)
2	Three full-height PCI-X 133-MHz adapter card slots	9	Video (VGA) port
3	Ground studs (used for grounding DC power supply)	10	NIC 2 (10/100/1000 Mb/s) port
4	Power supply 1 (DC shown) ¹	11	NIC 1 (10/100/1000 Mb/s) port
5	Power supply 2 (AC shown) ¹	12	RJ-45 serial (console) port (shared with the front-panel connector)
6	NIC 3 (10/100/1000 Mb/s) port ² (optional)	13	PS/2 connectors (keyboard and mouse)
7	NIC 4 (10/100/1000 Mb/s) port ² (optional)		

1. Two different power supplies (one AC and one DC) are shown together, for illustration purposes only. An actual configuration cannot have both power supplies together. The appliance includes either two AC or two DC power supplies or one AC power supply and a blank filler panel or one DC power supply and a blank filler panel.
2. NIC connectors are numbered so that 4 is to the left of 3 (see locations 7 and 6 in [Figure 1-5](#), respectively). On the appliance rear panel looking from left to right, the NIC port numbering is 1, 2, 4, 3 (see locations 11, 10, 7, and 6 in [Figure 1-5](#), respectively). If neither of the optional NIC connectors (4 and 3) are installed, an EMI filler panel occupies this space.

NIC LEDs

The rear of the Cisco ADE 2130 and 2140 Series appliance includes LEDs (a green LED to the left of the connector and a bi-color [green/amber] LED to the right of the connector) that indicate the connection activity and speed of the NIC ports. (See [Figure 1-6](#).)

[Table 1-6 on page 1-10](#) describes the activity and connection speed associated with the NIC 1 and NIC 2 LEDs.



Note

NIC ports 3 and 4 are optional using a mezzanine module on the Cisco ADE 2130 and 2140 Series appliance and might not be installed.

Figure 1-6 NIC LEDs

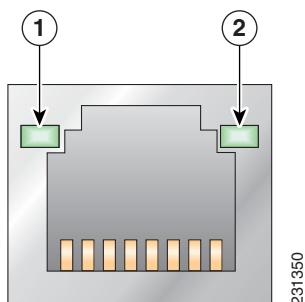

Table 1-6 NIC LEDs

LED	Color	State	Description
Left (location 1)		Off	10-Mb/s connection
	Green	Solid	100-Mb/s connection
	Amber	Solid	1000-Mb/s (or 1-Gb/s) connection
Right (location 2)		Off	No network connection
	Green	Solid	Network connection
	Green	Blinking	Transmit/receive activity

AC and DC Power Supply LEDs

The rear of Cisco ADE 2130 and 2140 Series appliance includes LEDs that indicate the power status of the AC and DC power supplies. (See locations 4 and 5 in [Figure 1-5 on page 1-9](#).)

[Table 1-7](#) describes the power status associated with the AC power supply LEDs. [Table 1-8](#) describes the power status associated with the DC power supply LEDs.

Table 1-7 AC Power Supply LED

LED	Color	State	Description
Below AC power supply input connector		Off	No AC input power to power supply
	Green	Blinking	AC power applied to power supply and standby voltages are available
	Green	Solid	All power available
	Amber	Blinking	AC power supply warning due to overcurrent or overtemperature condition or slow fan
	Amber	Solid	AC power supply failed or shut down due to blown fuse, high overcurrent or overtemperature condition, or fan failure

Table 1-8 DC Power Supply LED

LED	Color	State	Description
Below DC power supply input connector		Off	No DC input power to power supply
	Green	Blinking	DC power applied to power supply and standby voltages are available
	Green	Solid	All power available
	Amber	Blinking	DC power supply warning due to overcurrent or overtemperature condition or slow fan
	Amber	Solid	DC power supply failed or shut down due to blown fuse, high overcurrent or overtemperature condition, or fan failure

Input/Output Ports and Connectors

The Cisco ADE 2130 and 2140 Series appliance supports the following I/O connectors on the rear of the appliance:

- Ethernet connectors
- Serial connector
- Video connector
- Mouse connector
- Keyboard connector



Warning

To avoid electric shock, do not connect safety extra-low voltage (SELV) circuits to telephone-network voltage (TNV) circuits. LAN ports contain SELV circuits, and WAN ports contain TNV circuits. Some LAN and WAN ports both use RJ-45 connectors. Use caution when connecting cables. Statement 1021

Ethernet Port (NIC 1 and NIC 2)

The Cisco ADE 2130 and 2140 Series appliance comes with two integrated dual-port Ethernet controllers (1 and 2). These controllers provide an interface for connecting to 10-Mb/s, 100-Mb/s, or 1000-Mb/s networks and provide full-duplex (FDX) capability, which enables simultaneous transmission and reception of data on the Ethernet local-area network (LAN).

The appliance comes with an Ethernet RJ-45-to-RJ-45 yellow cable.



Note

(Optional) NIC ports 3 and 4 can be installed using a mezzanine module on the appliance. Additionally, the NIC LEDs for these ports are located on the bottom and not the top as for the NIC 1 and 2.

To access the Ethernet port, connect a Category 3, 4, 5, 5E, or 6 unshielded twisted-pair (UTP) cable to the RJ-45 connector on the back of the appliance. (See [Table 1-9](#).)

Table 1-9 Ethernet Cabling Guidelines

Type	Description
10BASE-T	EIA Categories 3, 4, or 5 UTP (2 or 4 pairs) up to 328 ft (100 m)
100BASE-TX	EIA Category 5 UTP (2 pairs) up to 328 ft (100 m)
1000BASE-T	EIA Category 6 (recommended), Category 5E or 5 UTP (2 pairs) up to 328 ft (100 m)

Ethernet Port Connector

Figure 1-7 shows the Ethernet RJ-45 port and plug.

Figure 1-7 RJ-45 Port and Plug

Table 1-10 lists the RJ-45 pin signals used on the connector.

Table 1-10 Ethernet Port Pinout

Ethernet Port Pin	Signal	Description
1	BI_DA+	Bidirectional pair A, +
2	BI_DA-	Bidirectional pair A, -
3	BI_DB+	Bidirectional pair B, +
4	BI_DC+	Bidirectional pair C, +
5	BI_DC-	Bidirectional pair C, -
6	BI_DB-	Bidirectional pair B, -
7	BI_DD+	Bidirectional pair D, +
8	BI_DD-	Bidirectional pair D, -

Serial (Console) Port

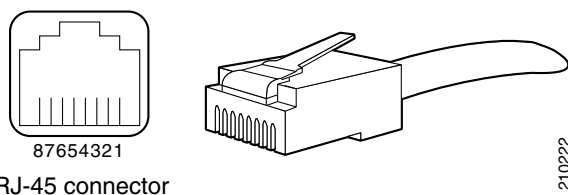
The Cisco ADE 2130 and 2140 Series appliance has two standard serial (console) ports. The appliance comes with a console port cable kit, which contains the cable and adapter to connect a console terminal (an ASCII terminal or PC running terminal-emulation software). The console cable kit includes the following items:

- RJ-45-to-RJ-45 rollover cable (light blue)
- RJ-45-to-DB-9 female DTE adapter (labeled TERMINAL)

Use the configuration/setup utility program to change the port address assignments.

**Note**

The configuration/setup utility program is located in the Cisco ADE 2130 and 2140 Series appliance ROM and can be accessed through the serial (console) port.

Serial (Console) Port Connector

The Cisco ADE 2130 and 2140 Series appliance has an RJ-45 serial port connector located on the back of the appliance. This connector is shared with the RJ-45 serial port connector located on the front panel.

**Note**

When one RJ-45 serial port connector is in use, the other is disabled. For example, if the rear-panel RJ-45 serial port connector is in use, the front-panel RJ-45 serial port connector is disabled and vice versa.

Figure 1-8 shows the pin number assignments for the RJ-45 serial (console) port connector on the back or front of the appliance. These pin number assignments conform to industry standards.

Figure 1-8 Serial Port Connector

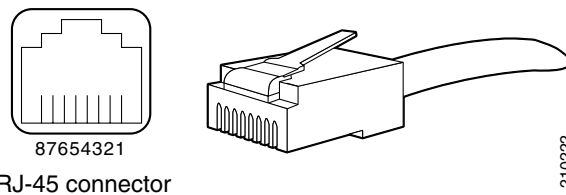
**Note**

The serial (console) RJ-45 port pinout differs slightly between the front- and rear-panel ports, specifically in relation to Pin 6 and Pin 7.

On the front-panel serial (console) port, Pin 6 is used as a serial port selection input. Grounding the signal on Pin 6 disables the rear-panel serial (console) port so that the front-panel port is active. This feature allows you to plug into and use the front-panel port without regard to whether anything is connected to the rear-panel port.

Table 1-11 lists the front-panel serial (console) port pinout descriptions.

Table 1-11 Front-Panel RJ-45 Serial (Console) Port Pinout

Serial Port Pin	Signal	Description
1	RTS	Request to send
2	DTR	Data terminal ready
3	TXD	Transmit data
4	GND	Earth ground
5	In Use	When grounded, indicates that the port is routed to the front-panel port.
6	RXD	Receive data
7	DSR	Data set ready
8	CTS	Clear to send

On the rear-panel serial (console) port, Pin 7 can be configured with a jumper located on the appliance motherboard. This jumper allows you to set Pin 7 to either Data Set Ready (DSR) or Data Carrier Detect (DCD) as might be required when using a serial port concentrator. The default jumper configuration selects the DSR signal, which conforms to the Cisco serial port standard.

Table 1-12 on page 1-14 shows the rear-panel serial (console) port pinout description.

Table 1-12 Rear-Panel RJ-45 Serial (Console) Port Pinout

Serial Port Pin	Signal	Description
1	RTS	Request to send
2	DTR	Data terminal ready
3	TXD	Transmit data
4	GND	Earth ground
5	GND	Earth ground
6	RXD	Receive data
7	DSR or DCD ¹	Data set ready or Data carrier detect
8	CTS	Clear to send

1. A jumper block on the appliance motherboard determines whether DSR or DCD is routed to Pin 7. The appliance motherboard has the jumper block preconfigured with DSR enabled.

Serial (Console) Port Cables

Use the thin, flat, RJ-45-to-RJ-45 rollover cable and the RJ-45-to-DB-9 female DTE adapter (labeled TERMINAL) to connect the console port to an ASCII terminal or a PC running terminal-emulation software. Table 1-13 lists the pinouts for the asynchronous serial console port, the RJ-45-to-RJ-45 rollover cable, and the RJ-45-to-DB-9 female DTE adapter.

Table 1-13 Serial Console Port Signaling and Cabling Using a DB-9 Adapter

Console Port (DTE)	RJ-45-to-RJ-45 Rollover Cable		RJ-45-to-DB-9 Terminal Adapter (Connected to Rollover Cable)	Console Device	
	Signal	RJ-45 Pin	RJ-45 Pin		DB-9 Pin
RTS		1 ¹	8	8	CTS
DTR		2	7	6	DSR
TXD		3	6	2	RXD
GND		4	5	5	GND
GND		5	4	5	GND
RXD		6	3	3	TXD
DSR		7	2	4	DTR
CTS		8 ¹	1	7	RTS

1. Pin 1 is connected internally to pin 8.

AC and DC Power Supplies

The Cisco ADE 2130 and 2140 Series appliance is equipped with either a 110-V or 220-V AC power supply or a –48-V to –60-V DC power supply (see locations 4 and 5 in [Figure 1-5 on page 1-9](#)).

**Note**

[Figure 1-5 on page 1-9](#) shows an AC and DC power supply together for illustration purposes. Never install an AC or DC power supply in the same appliance.

Both power supplies are capable of operating in redundant mode. A power supply blank filler panel is used for the empty power supply slot and is supplied with an appliance without redundancy.

The power supply is rated for 600-W output capacity in full AC or DC input voltage.

Each power supply incorporates a single 40-mm fan for cooling, which also contributes to overall appliance cooling. The cooling air enters the power supply from the power distribution side. If airflow through the power supply is insufficient, the overtemperature protection circuits activate a shutdown before the temperature passes the maximum rated temperature.

**Caution**

To ensure proper cooling if only one power supply is installed, the power supply must be in the right-hand slot and the power supply blank filler panel must be in the left-hand slot. (See [Figure 4-10 on page 4-20](#).)

**Warning**

Blank faceplates and cover panels serve three important functions: they prevent exposure to hazardous voltages and currents inside the chassis; they contain electromagnetic interference (EMI) that might disrupt other equipment; and they direct the flow of cooling air through the chassis. Do not operate the system unless all cards, faceplates, front covers, and rear covers are in place.

Statement 1029

To maintain hot-swap capability, ensure that an active power supply is in both power supply slots before replacing (hot-swapping) a power supply. Check the power supply LED to determine which power supply module has failed. (See location 2 in [Figure 4-9 on page 4-18](#) for either AC or DC power supply.)

**Warning**

Never install an AC power module and a DC power module in the same chassis. Statement 1050

AC Power Supply Input

A single receptacle is provided at the rear of the AC power supply for AC input.

DC Power Supply Input

The Cisco ADE 2130 and 2140 Series appliance uses a small, two-wire DC power Molex terminal block connector for input to the power supply.

With the connector installed in the appliance, the pins from top to bottom of the DC power terminal block are labeled – and +, respectively.

[Table 1-14](#) lists the pinout configuration for the connector.

Table 1-14 Power Supply Connector Pinouts

Pin Label	-48 VDC Power Source
-	-48 VDC
+	RTN (reference)

Environmental Monitoring

The Cisco ADE 2130 and 2140 Series appliance has protection circuits that monitor and detect overcurrent, overvoltage, and overtemperature conditions inside the appliance. If the power supply shuts down or latches off, a cycle of off for 15 seconds and on for 1 second will reset the power supply.

Overcurrent Protection (OCP)

The power supply shuts down and latches off after an overcurrent condition occurs. This latch is cleared by a power interruption.

Note

The power supply will not be damaged from power cycling.

Overvoltage Protection (OVP)

The power supply shuts down and latches off after an overvoltage condition occurs. This latch is cleared by a power interruption.

Overtemperature Protection (OTP)

The power supply is protected against overtemperature conditions caused by the loss of fan cooling or excessive ambient temperature. In an OTP condition, the power supply will shut down. When the power supply temperature drops to the rated safety limit, the power supply restores power automatically.

Regulatory Compliance

For regulatory compliance and safety information, see the Cisco *Regulatory Compliance and Safety Information for the Cisco Application Deployment Engine (ADE) 2130 and 2140 Series Appliance* document. This document is provided with the Cisco ADE 2130 and 2140 Series appliance and is also available online at Cisco.com (see the [“Obtaining Documentation and Submitting a Service Request”](#) section on page xv for more information).



CHAPTER 2

Preparing to Install the Cisco ADE 2130 and 2140 Series Appliance

This chapter describes the tasks you must perform before you install a Cisco ADE 2130 and 2140 Series appliance.

This chapter contains the following sections:

- [Safety Guidelines, page 2-2](#)
- [Preparing Your Site for Installation, page 2-6](#)
- [Ethernet and Console Port Considerations, page 2-16](#)



Warning

Only trained and qualified personnel should be allowed to install, replace, or service this equipment. This equipment contains an energy hazard. Disconnect the system before servicing. Statement 186



Warning

Read the installation instructions before you connect the system to its power source. Statement 10



Note

Read the *Regulatory Compliance and Safety Information for the Cisco Application Deployment Engine (ADE) 2130 and 2140 Series Appliance* document and the *Site Preparation and Safety Guide* that came with your Cisco ADE 2130 and 2140 Series appliance before you begin the installation.

Safety Guidelines

Before you begin installing the Cisco ADE 2130 and 2140 Series appliance, review the safety guidelines in this chapter and the [“Rack-Mounting Configuration Guidelines”](#) section on page 3-2 to avoid injuring yourself or damaging the equipment.

In addition, before replacing, configuring, or maintaining the appliance, review the safety warnings listed in the [“Safety Warnings”](#) section on page x and in the *Cisco Regulatory Compliance and Safety Information for the Cisco Application Deployment Engine (ADE) 2130 and 2140 Series Appliance* document.

General Precautions

Observe the following general precautions for using and working with your appliance:

- Observe and follow service markings. Do not service any Cisco product except as explained in your appliance documentation. Opening or removing covers that are marked with the triangular symbol with a lightning bolt may expose you to electrical shock. Components inside these compartments should be serviced only by an authorized service technician.
- If any of the following conditions occur, unplug the product from the electrical outlet and replace the part or contact your authorized service provider:
 - The power cable or plug is damaged.
 - An object has fallen into the product.
 - The product has been exposed to water.
 - The product has been dropped or damaged.
 - The product does not operate correctly when you follow the operating instructions.
- Keep your appliance away from radiators and heat sources. Also, do not block cooling vents.
- Do not spill food or liquids on your appliance, and never operate the product in a wet environment.
- Do not push any objects into the openings of your appliance. Doing so can cause fire or electric shock by shorting out interior components.
- Use the product only with other equipment approved by Cisco.
- Allow the product to cool before removing covers or touching internal components.
- Use the correct external power source. Operate the product only from the type of power source indicated on the electrical ratings label. If you are not sure of the type of power source required, consult your service representative or local power company.
- Use only approved power cables. If you have not been provided with a power cable for your appliance or for any AC-powered option intended for your appliance, purchase a power cable that is approved for use in your country. The power cable must be rated for the product and for the voltage and current marked on the product’s electrical ratings label. The voltage and current rating of the cable should be greater than the ratings marked on the product.
- To help prevent electric shock, plug the appliance and power cables into properly grounded electrical outlets. These cables are equipped with three-prong plugs to help ensure proper grounding. Do not use adapter plugs or remove the grounding prong from a cable.
- Do not use appliance or voltage converters or kits sold for appliances with your product.
- To help protect your appliance from sudden, transient increases and decreases in electrical power, use a surge suppressor, line conditioner, or uninterruptible power supply (UPS).

- Position cables and power cords carefully; route cables and the power cord and plug so that they cannot be stepped on or tripped over. Be sure that nothing rests on your appliance cables or power cord.
- Do not modify power cables or plugs. Consult a licensed electrician or your power company for site modifications. Always follow your local or national wiring rules.

Safety with Equipment

The following guidelines will help ensure your safety and protect the equipment. This list does not include potentially hazardous situations, so be *alert*.



Warning

Read the installation instructions before connecting the system to the power source. Statement 1004

- Always disconnect all power cords and interface cables before moving the appliance.
- Never assume that power is disconnected from a circuit; *always* check.
- Keep the appliance chassis area clear and dust-free before and after installation.
- Keep tools and assembly components away from walk areas where you or others could fall over them.
- Do not work alone if potentially hazardous conditions exist.
- Do not perform any action that creates a potential hazard to people or makes the equipment unsafe.
- Do not wear loose clothing that may get caught in the appliance chassis.
- Wear safety glasses when working under conditions that may be hazardous to your eyes.

Safety with Electricity



Warning

This unit is intended for installation in restricted access areas. A restricted access area can be accessed only through the use of a special tool, lock and key, or other means of security. Statement 1017



Warning

To avoid electric shock, do not connect safety extra-low voltage (SELV) circuits to telephone-network voltage (TNV) circuits. LAN ports contain SELV circuits, and WAN ports contain TNV circuits. Some LAN and WAN ports both use RJ-45 connectors. Statement 1021



Warning

Do not touch the power supply when the power cord is connected. For systems with a power switch, line voltages are present within the power supply even when the power switch is off and the power cord is connected. For systems without a power switch, line voltages are present within the power supply when the power cord is connected. Statement 4

**Warning**

Before working on equipment that is connected to power lines, remove jewelry (including rings, necklaces, and watches). Metal objects will heat up when connected to power and ground and can cause serious burns or weld the metal object to the terminals. Statement 43

**Warning**

Before working on a chassis or working near power supplies, unplug the power cord on AC units; disconnect the power at the circuit breaker on DC units. Statement 12

**Warning**

Before working on a chassis or working near power supplies, unplug the power cord on AC units. Statement 246

**Warning**

The plug-socket combination must be accessible at all times, because it serves as the main disconnecting device. Statement 1019

**Warning**

Installation of the equipment must comply with local and national electrical codes. Statement 1074

**Warning**

Hazardous voltage or energy may be present on DC power terminals. Always replace cover when terminals are not in service. Be sure uninsulated conductors are not accessible when cover is in place. Statement 1075

**Warning**

Do not work on the system or connect or disconnect cables during periods of lightning activity. Statement 1001

**Warning**

This equipment is intended to be grounded. Ensure that the host is connected to earth ground during normal use. Statement 39

**Warning**

When installing or replacing the unit, the ground connection must always be made first and disconnected last. Statement 1046

Follow these guidelines when working on equipment powered by electricity:

- Locate the room's emergency power-off switch. Then, if an electrical accident occurs, you can quickly turn off the power.
- Disconnect all power before doing the following:
 - Working on or near power supplies
 - Installing or removing an appliance
 - Performing most hardware upgrades
- Never install equipment that appears damaged.

- Carefully examine your work area for possible hazards, such as moist floors, ungrounded power extension cables, and missing safety grounds.
- Never assume that power is disconnected from a circuit; *always* check.
- Never perform any action that creates a potential hazard to people or makes the equipment unsafe.
- Never work alone when potentially hazardous conditions exist.
- If an electrical accident occurs, proceed as follows:
 - Use caution, and do not become a victim yourself.
 - Turn off power to the appliance.
 - If possible, send another person to get medical aid. Otherwise, determine the condition of the victim, and then call for help.
 - Determine whether the person needs rescue breathing, external cardiac compressions, or other medical attention; then take appropriate action.

In addition, use the following guidelines when working with any equipment that is disconnected from a power source but still connected to telephone wiring or network cabling:

- Never install telephone wiring during a lightning storm.
- Never install telephone jacks in wet locations unless the jack is specifically designed for it.
- Never touch uninsulated telephone wires or terminals unless the telephone line is disconnected at the network interface.
- Use caution when installing or modifying telephone lines.

Preventing Electrostatic Discharge Damage

Electrostatic discharge (ESD) can damage equipment and impair electrical circuitry. ESD can occur when electronic printed circuit cards are improperly handled and can cause complete or intermittent failures. Always follow ESD-prevention procedures when removing and replacing components:

- When unpacking a static-sensitive component from its shipping carton, do not remove the component from the antistatic packing material until you are ready to install the component in your appliance. Just before unwrapping the antistatic packaging, be sure to discharge static electricity from your body.
- When transporting a sensitive component, first place it in an antistatic container or packaging.
- Handle all sensitive components in a static-safe area. If possible, use antistatic floor pads and workbench pads.
- Ensure that the Cisco ADE 2130 and 2140 Series appliance is electrically connected to earth ground.
- Wear an ESD-preventive wrist strap, ensuring that it makes good skin contact. Attach the antistatic wrist strap to your wrist and connect its cord to the ESD socket on the top, left-hand side on the front of the appliance to channel unwanted ESD voltages safely to ground. To guard against ESD damage and shocks, the wrist strap and cord must operate effectively. If no wrist strap is available, ground yourself by touching a metal part of the appliance.



Caution

For the safety of your equipment, periodically check the resistance value of the antistatic wrist strap. It should be between 1 and 10 Mohm.

Lifting Guidelines

A Cisco ADE 2130 or 2140 Series appliance weighs between 30 lb (13.6 kg) and 51.5 lb (23.4 kg) depending on what hardware options are installed in the appliance. The appliance is not intended to be moved frequently. Before you install the appliance, ensure that your site is properly prepared so you can avoid having to move the appliance later to accommodate power sources and network connections.

Whenever you lift the appliance or any heavy object, follow these guidelines:

- Always disconnect all external cables before lifting or moving the appliance.
- Ensure that your footing is solid, and balance the weight of the object between your feet.
- Lift the appliance slowly; never move suddenly or twist your body as you lift.
- Keep your back straight and lift with your legs, not your back. If you must bend down to lift the appliance, bend at the knees, not at the waist, to reduce the strain on your lower back muscles.
- Lift the appliance from the bottom and grasp the underside of the appliance exterior with both hands.

Preparing Your Site for Installation

Before installing the Cisco ADE 2130 and 2140 Series appliance, it is important to prepare for installation by:

- Preparing the site (site planning) and reviewing the installation plans or method of procedures (MOPs)
- Unpacking and inspecting the appliance
- Gathering tools and test equipment required to properly install the appliance

Site Planning



Warning

This unit is intended for installation in restricted access areas. A restricted access area can be accessed only through the use of a special tool, lock and key, or other means of security.

Statement 1017

Typically, you should have prepared the installation site beforehand. As part of your preparation, obtain a floor plan of the site and the equipment rack where the Cisco ADE 2130 and 2140 Series appliance will be housed. Determine the location of any existing appliances and their interconnections, including communications and power. Following the airflow guidelines (see the [“Airflow Guidelines” section on page 2-9](#)) ensures that adequate cooling air is provided to the appliance.

All personnel involved in the installation of the appliance including installers, engineers, and supervisors should participate in the preparation of a MOP for approval by the customer. (See the [“Method of Procedure” section on page 2-11](#).)

The following sections provide the site requirement guidelines that you must consider before installing the appliance:

- [Rack Installation Safety Guidelines, page 2-7](#)
- [Site Environment, page 2-8](#)
- [Airflow Guidelines, page 2-9](#)

- [Temperature and Humidity Guidelines](#), page 2-9
- [Power Considerations](#), page 2-10
- [Method of Procedure](#), page 2-11

Rack Installation Safety Guidelines

The Cisco ADE 2130 and 2140 Series appliance can be mounted in most 2-post, 4-post, or telco-type 19-inch equipment racks that comply with the Electronics Industries Association (EIA) standard for equipment racks (EIA-310-D). The rack must have at least two posts with mounting flanges to mount the appliance. The distance between the center lines of the mounting holes on the two mounting posts must be 18.31 inches +/- 0.06 inch (46.50 cm +/- 0.15 cm). The rack-mounting hardware included with the appliance is suitable for most 19-inch equipment racks or telco-type frames.

Figure 2-1 shows examples of 4-post and 2-post (telco-type) equipment racks, respectively.

Figure 2-1 Equipment Rack Types

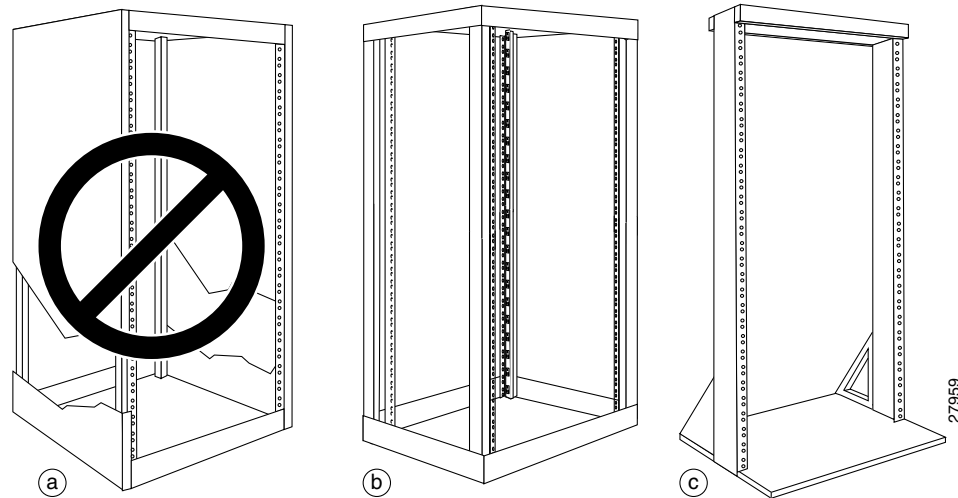

Enclosed Rack (Do Not Use)

Figure 2-1a shows a free-standing, enclosed rack with two mounting posts in the front. The Cisco ADE 2130 and 2140 Series appliance should *not* be installed in this type of enclosed rack, because the appliance requires an unobstructed flow of cooling air to maintain acceptable operating temperatures for its internal components. Installing the appliance in any type of enclosed rack—even with the front and back doors removed—could disrupt the airflow, trap heat next to the appliance, and cause an overtemperature condition inside the appliance.

4-Post (Open) Rack

Figure 2-1b shows a free-standing, 4-post open rack with two mounting posts in front and two mounting posts in back. The mounting posts in this type of rack are often adjustable so that you can position the rack-mounted unit within the depth of the rack rather than flush-mount it with the front of the rack.

2-Post (Telco) Rack

Figure 2-1c shows a 2-post (telco-type) rack. This rack is an open frame consisting of two posts tied together by a crossbar at the top and a floor stand at the bottom.

This type of rack is usually secured to the floor and sometimes to an overhead structure or wall for additional stability. The Cisco ADE 2130 or 2140 Series appliance can be installed in this rack either in a front-mounted position or a mid-mounted position.

- In the front-mounted position, you secure the appliance rack-mounting brackets directly to the rack posts.
- In the mid-mounted position, you secure a set of optional mid-mount brackets to the rack posts. The appliance rack-mounting flanges are then secured to the mid-mount brackets. The mid-mounted position moves the center of gravity closer to the appliance and closer to the vertical axis of the rack posts, which adds to the stability of the rack installation.

Before installing your Cisco ADE 2130 and 2140 Series appliance in a rack, review the following guidelines:

- Two or more people are required to install the appliance in a rack.
- Ensure that the room air temperature is below 95°F (35°C).
- Do not block any air vents; usually 6 inches (15 cm) of space provides proper airflow.
- Plan the appliance installation starting from the bottom of the rack.
- Do not extend more than one appliance out of the rack at the same time.
- Connect the appliance to a properly grounded outlet.
- Do not overload the power outlet when installing multiple devices in the rack.
- Do not place any object weighing more than 110 lb (50 kg) on top of rack-mounted devices.

Site Environment

The location of your appliance and the layout of your equipment rack or wiring room are important considerations for proper operation. Equipment placed too close together, inadequate ventilation, and inaccessible panels can cause malfunctions and shutdowns, and can make maintenance difficult. Plan for access to front and rear panels of the appliance.

The following precautions will help you plan an acceptable operating environment for your appliance and will help you avoid environmentally caused equipment failures:

- Ensure that the room where your appliance operates has adequate circulation. Electrical equipment generates heat. Without adequate circulation, ambient air temperature may not cool equipment to acceptable operating temperatures (see the [“Airflow Guidelines” section on page 2-9](#)).
- Ensure the site of the rack includes provisions for source AC power, grounding, and network cables.
- Allow sufficient space to work around the rack during the installation. You need:
 - At least 3 feet (9.14 m) adjacent to the rack to move, align, and insert the appliance.
 - At least 24 inches (61 cm) of clearance in front of and behind the appliance for maintenance after installation.
- To mount the appliance between two posts or rails, the usable aperture (the width between the *inner* edges of the two mounting flanges) must be at least 17.7 inches (45.0 cm).
- If you use a 2-post (telco-type) rack, the weight of several appliances is cantilevered off of the two rack posts. Make sure that:

- The weight of several appliances does not make the frame unstable.
- The frame is bolted to the floor and is secured to the building structure using either wall brackets or overhead brackets.
- Use appropriate strain-relief methods to protect cables and equipment connections.
- To avoid noise interference in network interface cables, do not route them directly across or along power cables.
- Always follow ESD-prevention procedures as described in the “[Preventing Electrostatic Discharge Damage](#)” section on page 2-5 to avoid damage to equipment. Damage from static discharge can cause immediate or intermittent equipment failure.

Airflow Guidelines



Warning

Blank faceplates and cover panels serve three important functions: they prevent exposure to hazardous voltages and currents inside the chassis; they contain electromagnetic interference (EMI) that might disrupt other equipment; and they direct the flow of cooling air through the chassis. Do not operate the system unless all cards, faceplates, front covers, and rear covers are in place.

Statement 1029

To ensure adequate airflow through the equipment rack, it is recommended that you maintain a clearance of at least 6 inches (15.24 cm) at the front and the rear of the rack.

If airflow through the equipment rack and the appliances that occupy it is blocked or restricted, or if the ambient air being drawn into the rack is too warm, an overtemperature condition within the rack and the appliances that occupy it can occur.

The site should also be as dust-free as possible. Dust tends to clog the appliance fans, reducing the flow of cooling air through the equipment rack and the appliances that occupy it. This reduction increases the risk of an overtemperature condition.

Additionally, the following guidelines will help you plan your equipment rack configuration:

- Besides airflow, you must allow clearance around the rack for maintenance.
- When mounting an appliance in an open rack, ensure that the rack frame does not block the front intakes or the rear exhausts.

Temperature and Humidity Guidelines

[Table 2-1 on page 2-10](#) lists the operating and nonoperating environmental site requirements for the Cisco ADE 2130 and 2140 Series appliance. The appliance normally operates within the ranges listed; however, if a temperature measurement approaching a minimum or maximum parameter indicates a potential problem. Maintain normal operation by anticipating and correcting environmental anomalies before they approach critical values by properly planning and preparing your site before you install the appliance.



Warning

To prevent the system from overheating, do not operate it in an area that exceeds the maximum recommended ambient temperature of: 95°F (35°C). Statement 1047

Table 2-1 Operating and Nonoperating Environmental Specifications

Specification	Minimum	Maximum
Temperature, ambient operating	50°F (10°C)	95°F (35°C)
Temperature, ambient nonoperating and storage	-40°F (°C)	158°F (70°C)
Humidity, ambient (noncondensing) operating	5%	85%
Humidity, ambient (noncondensing) nonoperating and storage	50%	90%
Vibration, operating	5–500 Hz, 2.20 g RMS random	—

Power Considerations

You configure your Cisco ADE 2130 and 2140 Series appliance with either an AC-input or DC-input power supply. (For power supply pinout descriptions, see the [“AC and DC Power Supplies” section on page 1-15.](#)) Both power supplies are hot-swappable. You can configure your appliance for redundancy with either:

- Two AC-input power supplies
- Two DC-input power supplies

Or, you can choose either one AC-input or one DC-input power supply for nonredundancy.



Warning

Blank faceplates and cover panels serve three important functions: they prevent exposure to hazardous voltages and currents inside the chassis; they contain electromagnetic interference (EMI) that might disrupt other equipment; and they direct the flow of cooling air through the chassis. Do not operate the system unless all cards, faceplates, front covers, and rear covers are in place.

Statement 1029

When the appliance is configured with two power supply modules, the hot-swap feature allows you to replace a failed power supply without interrupting the appliance operation. During this hot-swap replacement, a maximum of two minutes is recommended.



Caution

If only one power supply is installed, it must be in the right-hand slot and a power supply blank filler panel must be installed in the left-hand slot to ensure proper cooling. (See location 5 in [Figure 1-5 on page 1-9.](#))



Warning

Never install an AC power module and a DC power module in the same chassis. Statement 1050

AC Power Supply Safety Considerations

Ensure all power connections conform to the rules and regulations in the National Electrical Codes (NECs), as well as local codes. Follow these precautions and recommendations when planning power connections to your appliance:

- Check the power at your site before installation and periodically after installation to ensure that you are receiving clean power (free of spikes and noise). Install a power conditioner if necessary.
- The AC power supply includes the following features:

- Autoselects either 110-V or 220-V operation.
- All appliances include an electrical cord. (A label near the power cord indicates the correct voltage, frequency, current draw, and power dissipation for the appliance.)

**Warning**

This product relies on the building's installation for short-circuit (overcurrent) protection. Ensure that fuse or circuit breaker no larger than 120 VAC, 15A U.S. (240 VAC, 10A international) is used on the phase conductors (all current-carrying conductors). Statement 13

- Install proper grounding to your appliance and host equipment rack to avoid damage from lightning and power surges.

**Warning**

This equipment must be grounded. Never defeat the ground conductor or operate the equipment in the absence of a suitably installed ground conductor. Contact appropriate electrical inspection authority or an electrician if you are uncertain that suitable grounding is available. Statement 1024

- The AC-input power supply operates on input voltage and frequency within the ranges of 100 to 240 VRMS and 50/60 Hz without the need for operator adjustments.

DC Power Supply Safety Considerations

Follow these precautions and recommendations when planning power connections to your appliance:

- Check the power at your site before installation and periodically after installation to ensure that you are receiving clean power (free of spikes and noise). Install a power conditioner if necessary.
- The DC power supply includes the following features:
 - –48-VDC to –60-VDC operation

**Warning**

This product relies on the building's installation for short-circuit (overcurrent) protection. Ensure that fuse or circuit breaker no larger than 120 VAC, 15A U.S. (240 VAC, 10A international) is used on the phase conductors (all current-carrying conductors). Statement 13

- Install proper grounding to your appliance and host equipment rack to avoid damage from lightning and power surges.

**Warning**

This equipment must be grounded. Never defeat the ground conductor or operate the equipment in the absence of a suitably installed ground conductor. Contact appropriate electrical inspection authority or an electrician if you are uncertain that suitable grounding is available. Statement 1024

Method of Procedure

As described previously, part of your preparation includes reviewing installation plans or MOPs. An example of a MOP (a preinstallation checklist of tasks and considerations that need to be addressed and agreed upon before proceeding with the installation) is as follows:

1. Assign personnel.
2. Determine protection requirements for personnel, equipment, and tools.
3. Evaluate potential hazards that may affect service.

4. Schedule time for installation.
5. Determine any space requirements.
6. Determine any power requirements.
7. Identify any required procedures or tests.
8. On an equipment plan, make a preliminary decision that locates each Cisco ADE 2130 and 2140 Series appliance that you plan to install.
9. Read this hardware installation guide.
10. Verify the list of replaceable parts for installation (screws, bolts, washers, and so on) so that the parts are identified.
11. Check the required tools list to make sure the necessary tools and test equipment are available. (See the [“Required Tools and Equipment”](#) section on page 2-14.)
12. Perform the installation.

Unpacking and Checking the Contents of Your Shipment

The shipping package for the Cisco ADE 2130 and 2140 Series appliance is designed to reduce the possibility of product damage associated with routine material handling experienced during shipment. To reduce the potential damage to the product, transport the appliance in its original Cisco packaging. Failure to do so may result in damage to the appliance. Also, do not remove the appliance from its shipping container until you are ready to install it.

The appliance, cables, and any optional equipment you ordered may be shipped in more than one container. When you unpack the containers, check the packing list to ensure that you received all the parts listed in [Table 2-2](#). A *Notes* section has been provided to record damaged or missing items.



Note

Do not discard the packaging materials used in shipping your Cisco ADE 2130 and 2140 Series appliance. You will need the packaging materials in the future if you move or ship your appliance.

Table 2-2 Cisco ADE 2130 or 2140 Series Appliance Packing List

✓	Item	Cisco Part Number
<input type="checkbox"/>	Cisco Application Deployment Engine (ADE) 2130 Series Appliance	CADE-2130-K9
<input type="checkbox"/>	Cisco Application Deployment Engine (ADE) 2140 Series Appliance	CADE-2140-K9
<input type="checkbox"/>	2-post Rack-mount kit (For kit contents, see the “2-Post Rack-Mount Hardware Kit” section on page 3-4.)	CADE-2U-BRACKETS
<input type="checkbox"/>	4-post Server Rack-mount kit (For kit contents, see the “4-Post Rack-Mount Hardware Kit” section on page 3-7.)	CADE-2U-RAILS
<input type="checkbox"/>	<i>Cisco Information Packet</i>	78-5235-03D0
<input type="checkbox"/>	Cisco 90-Day Limited Hardware Warranty Terms	78-5236-01C0

Table 2-2 Cisco ADE 2130 or 2140 Series Appliance Packing List

✓	Item	Cisco Part Number
<input type="checkbox"/>	<i>Regulatory Compliance and Safety Information for the Cisco Application Deployment Engine (ADE) 2130 and 2140 Series Appliance</i>	78-18319-xx
<input type="checkbox"/>	<i>Cisco Application Deployment Engine (ADE) 2130 and 2140 Series Appliance Hardware Installation Guide</i>	78-18579-xx

Notes

Inspect all items for shipping damage. If anything appears to be damaged, or if you encounter problems installing or configuring your appliance, contact your customer service representative.

Cisco Information Packet and Warranty

The *Cisco Information Packet* provides warranty, service, and support information.

To access and download the *Cisco Information Packet* and your warranty and license agreements from Cisco.com:

Step 1 Launch your Internet browser, then go to this URL:

http://www.cisco.com/univercd/cc/td/doc/es_inpck/cetrans.htm

The Warranties and License Agreements page appears.

Step 2 To read the *Cisco Information Packet*:

- a. Click the **Information Packet Number** field, and make sure the part number 78-5235-03D0 is highlighted.
- b. Select the language in which you would like to read the document.
- c. Click **Go**.

The Cisco Limited Warranty and software License page from the Information Packet appears.

- d. Read the document online, or click the **PDF** icon to download and print the document.



Note You must have Adobe Acrobat Reader to view and print PDF files. You can download the reader from the Adobe website at: <http://www.adobe.com>

Step 3 To read translated and localized warranty information about your product:

- a. Enter this part number in the Warranty Document Number field:
78-5236-01C0
- b. Select the language in which you would like to read the document.
- c. Click **Go**.

The Cisco warranty page appears.

- d. Review the document online, or click the **PDF** icon to download and print the document in PDF.

Step 4 You can also contact the Cisco Service and Support website for assistance at:

<http://www.cisco.com/en/US/support/>

Duration of Hardware Warranty

Ninety (90) days.

Replacement, Repair, or Refund Policy for Hardware

Cisco or its service center will use commercially reasonable efforts to ship a replacement part within ten (10) working days after receipt of the Return Materials Authorization (RMA) request. Actual delivery times can vary depending on the customer location.

Cisco reserves the right to refund the purchase price as its exclusive warranty remedy.

To Receive a Return Materials Authorization (RMA) Number

Contact the company from whom you purchased the product. If you purchased the product directly from Cisco, contact your Cisco Sales and Service Representative.

Complete the information below, and keep it for reference:

Company product purchased from	
Company telephone number and website	
Product model number	
Product serial number ¹	
Maintenance contact number	

1. See the “Product Serial Number Location” section on page 1-3 and the “Product Serial Number Location” section on page A-7 for more information.

Required Tools and Equipment



Caution

The fastener pack, within the rack-mount kit, contains eight rack screws. You must check these screws to ensure that they are the appropriate size for the holes in your rack. Using the wrong-sized screws for your threaded rack holes can damage the rack.

You need the following tools and equipment to install the Cisco ADE 2130 and 2140 Series appliance in a 2- or 4-post rack:



Warning

Only trained and qualified personnel should be allowed to install, replace, or service this equipment.
Statement 1030

- ESD-preventive cord and wrist strap.
- Number 2 Phillips screwdriver.
- Flat-blade screwdrivers: small, 3/16-inch (0.476 cm) and medium, 1/4-inch (0.625 cm).
 - To remove the cover, if you are upgrading memory or other components

- Rack-Mount Kit (For kit contents, see the “[2-Post Rack-Mount Hardware Kit](#)” section on page 3-4 or the “[4-Post Rack-Mount Hardware Kit](#)” section on page 3-7.)
- Cables for connection to the LAN ports (depending on the configuration).
- Ethernet hub or PC with a network interface card for connection to the Ethernet (LAN) port or ports.
- Console terminal (an ASCII terminal or a PC running terminal-emulation software) that is configured for 9600 baud, 8 data bits, no parity, 1 stop bit, and no hardware flow control.
- Console cable for connection to the serial (console) port.

Installation Checklist

To assist you with your installation and to provide a historical record of what was done, and by whom, use the following Installation Checklist. Make a copy of this checklist and mark the entries as you complete each task. When the checklist is completed, include a copy of the checklist for each Cisco ADE 2130 and 2140 Series appliance in your Site Log (see the “[Creating a Site Log](#)” section on page 2-15 for information about creating a Site Log) along with other records for your new appliance.

Installation Checklist for Site:

Cisco Application Deployment Engine 2130 or 2140 Series Appliance Name:

Task	Verified by	Date
Installation Checklist copied		
Background information placed in Site Log		
Site power voltages verified		
Installation site power check completed		
Required tools available		
Additional equipment available		
ADE 2130 or 2140 Series appliance received		
<i>Cisco Information Packet</i> publication received		
Appliance components verified		
Initial electrical connections established		
ASCII terminal (for local configuration)		
Signal distance limits verified		
Startup sequence steps completed		
Initial operation verified		

Creating a Site Log

The Site Log (see [Appendix B, “Site Log,”](#) for a sample Site Log) provides a record of all actions related to installing and maintaining the Cisco ADE 2130 and 2140 Series appliance. Keep the log in an accessible place near the appliance so that anyone who performs tasks has access to it. Use the Installation Checklist (see the previous section, “[Installation Checklist](#)”) to verify the steps in the installation and maintenance of your appliance. Site Log entries might include the following:

- Installation progress—Make a copy of the appliance Installation Checklist, and insert it into the Site Log. Make entries as you complete each task.
- Upgrade, removal, and maintenance procedures—Use the Site Log as a record of ongoing appliance maintenance and expansion history. Each time a task is performed on the appliance, update the Site Log to reflect the following information:
 - Installation of new adapter cards
 - Removal or replacement of adapter cards and other upgrades
 - Configuration changes
 - Maintenance schedules and requirements
 - Maintenance procedures performed
 - Intermittent problems
 - Comments and notes

Ethernet and Console Port Considerations

There are two network interface connectors (NIC 1 and NIC 2) on the rear panel of the Cisco ADE 2130 and 2140 Series appliance. Both ports use unshielded twisted-pair (UTP) cable. Cisco recommends at least a Category 5, 5E, or 6 UTP cable. The maximum segment distance is 328 feet (100 meters). The UTP cables look like the cables used for ordinary telephones; however, UTP cables meet certain electrical standards that telephone cables do not. (See the [“Ethernet Port \(NIC 1 and NIC 2\)” section on page 1-11](#) for UTP cabling specifications.)



Note

Two additional NIC ports (3 and 4) can be installed on the rear panel with a NIC personality (mezzanine) card.

The appliance includes an asynchronous serial console port, which provides access to the appliance locally (using a console terminal). The following sections describe important cabling information to consider before connecting a console terminal—either an ASCII terminal or a PC running terminal-emulation software—to the console port. (See the [“Serial \(Console\) Port” section on page 1-12](#) for serial (console) cabling specifications.)

NIC 1 and NIC 2 (RJ-45) Ethernet Connections

The NIC 1 and NIC 2 connections support 10BASE-T, 100BASE-TX, and 1000BASE-T standards. The transmission speed of the Ethernet ports is autosensing by default and is user configurable.

[Figure 1-7 on page 1-12](#) shows the pin orientation of the RJ-45 Ethernet port and the modular cable plug it accepts.

Serial (Console) Port Connections

The console port on the Cisco ADE 2130 and 2140 Series appliance includes an EIA/TIA-232 asynchronous serial (RJ-45) connector. This serial console connector (port) allows you the capability to access the appliance locally by connecting a terminal—either a PC running terminal-emulation software or an ASCII terminal—to the console port.

To connect a PC running terminal-emulation software to the console port, use an RJ-45-to-RJ-45 rollover cable and an RJ-45-to-DB-9 female DTE adapter (labeled TERMINAL). (For more information, see the [“Serial \(Console\) Port” section on page 1-12.](#))

The default parameters for the console port are 9600 baud, 8 data bits, no parity, 1 stop bit, and no hardware flow control.



CHAPTER 3

Installing the Cisco ADE 2130 and 2140 Series Appliance

This chapter describes how to install your Cisco ADE 2130 and 2140 Series appliance and how to connect it to the network.

This chapter contains the following sections:

- [Rack-Mounting Configuration Guidelines, page 3-2](#)
- [Mounting the Cisco ADE 2130 and 2140 Series Appliance in a 2-Post Rack, page 3-3](#)
- [Mounting the Cisco ADE 2130 and 2140 Series Appliance in a 4-Post Rack, page 3-7](#)
- [Cisco ADE 2130 and 2140 Series Appliance Power, page 3-11](#)
- [Connecting the Network and Console Cables, page 3-18](#)
- [Powering Up the Cisco ADE 2130 and 2140 Series Appliance, page 3-20](#)
- [Removing or Replacing the Cisco ADE 2130 and 2140 Series Appliance, page 3-22](#)

Before you begin the installation, read the *Regulatory Compliance and Safety Information for the Cisco Application Deployment Engine (ADE) 2130 and 2140 Series Appliance* document and the *Site Preparation and Safety Guide* that shipped with your appliance.

Warning

Read the installation instructions before you connect the system to its power source. Statement 10

Warning

Only trained and qualified personnel should be allowed to install, replace, or service this equipment. This equipment contains an energy hazard. Disconnect the system before servicing. Statement 186

Warning

This unit is intended for installation in restricted access areas. A restricted access area can be accessed only through the use of a special tool, lock and key, or other means of security. Statement 1017

Warning

Before working on a system that has an on/off switch, turn OFF the power and unplug the power cord. Statement 1

**Warning**

To prevent personal injury or damage to the chassis, never attempt to lift or tilt the chassis using the handles on modules (such as power supplies, fans, or cards); these types of handles are not designed to support the weight of the unit. Statement 1032

**Warning**

Connect the unit only to DC power source that complies with the safety extra-low voltage (SELV) requirements in IEC 60950 based safety standards. Statement 1033

**Warning**

Do not touch the power supply when the power cord is connected. For systems with a power switch, line voltages are present within the power supply even when the power switch is off and the power cord is connected. For systems without a power switch, line voltages are present within the power supply when the power cord is connected. Statement 4

**Warning**

To prevent bodily injury when mounting or servicing this unit in a rack, you must take special precautions to ensure that the system remains stable. The following guidelines are provided to ensure your safety:

- This unit should be mounted at the bottom of the rack if it is the only unit in the rack.
- When mounting this unit in a partially filled rack, load the rack from the bottom to the top with the heaviest component at the bottom of the rack.
- If the rack is provided with stabilizing devices, install the stabilizers before mounting or servicing the unit in the rack. Statement 1006

Rack-Mounting Configuration Guidelines

You can mid-mount the appliance in a 19-inch (48.3-cm) equipment rack that conforms to the 2- and 4-post rack specification (the inside width of the rack should be 17.5 inches [44.45 cm]). When installed in the rack, the appliance requires two EIA 3.5-inch (8.9-cm) vertical mounting spaces or 2 rack units (RU) for mounting. (See the [“Mounting the Cisco ADE 2130 and 2140 Series Appliance in a 2-Post Rack”](#) section on page 3-3 or the [“Mounting the Cisco ADE 2130 and 2140 Series Appliance in a 4-Post Rack”](#) section on page 3-7.)

**Caution**

Clearance in the front and rear of the Cisco ADE 2130 and 2140 Series appliance must be allowed for cooling air to be drawn in through the front and circulated through the appliance and out the rear of the appliance.

The [“Rack Installation Safety Guidelines”](#) section on page 2-7 and the following information will help you plan your equipment rack configuration:

- When mounting the appliance to an equipment rack, ensure that the rack is bolted to the floor.
- Because you will probably be installing more than one appliance into the rack, ensure that the weight of all the appliances installed does not make the rack unstable.

**Caution**

Some equipment racks are also secured to ceiling brackets, if necessary, due to the weight of the equipment in the rack. Make sure that the rack you are using to install the appliances is secured to the building structure.

- As mentioned in the [“Airflow Guidelines” section on page 2-9](#), maintain a 6-inch (15.2-cm) clearance at the front and rear of the appliance to ensure adequate air intake and exhaust.
- Avoid installing the appliances in an overly congested rack. Air flowing to or from other appliances in the rack might interfere with the normal flow of cooling air through the appliances, increasing the potential for overtemperature conditions within the appliances. (See the [“Overtemperature Protection \(OTP\)” section on page 1-16](#) for more information about overtemperature conditions.)
- Allow at least 24 inches (61 cm) of clearance at the front and rear of the rack for appliance maintenance.

**Caution**

To prevent appliance overheating, never install the appliance in an enclosed rack or room that is not properly ventilated or air conditioned.

- Follow your local practices for cable management. Ensure that cables to and from the appliances do not impede access to perform equipment maintenance or upgrades.

Mounting the Cisco ADE 2130 and 2140 Series Appliance in a 2-Post Rack

Typically, the Cisco ADE 2130 and 2140 Series appliance mounts to a 19-inch (48.3-cm) 2-post equipment rack with rack-mounting brackets that attach to the front sides of the appliance. The inside width between the two posts or mounting strips (left and right) must be at least 17.5 inches (44.45 cm). See the [“Preparing Your Site for Installation” section on page 2-6](#) for information about the types of equipment racks.

Even though the intake and exhaust for cooling air are located on the front and on the rear of the appliance, respectively, it is recommended that multiple appliances be stacked in a rack with at least a 1.5-inch (3.81-cm) vertical clearance.

**Caution**

To prevent damage to the appliance, only use Cisco provided hardware and screws when installing the appliance.

To secure the appliance to the equipment rack, you must use the two 10-32 x 1/2-inch rack screws (see [Figure 3-1 on page 3-4](#) and [Table 3-1 on page 3-4](#)) for each side or follow your local practices for installing the appliance into your equipment rack. Ensure that the rack-mount brackets have been securely fastened. See the [“Attaching the L Brackets to the Appliance” section on page 3-5](#) for more information.

The following procedure provides a general outline for mounting the appliance into the equipment rack.

**Caution**

To prevent injury, review the “[Safety Guidelines](#)” section on page 2-2 and the “[Rack-Mounting Configuration Guidelines](#)” section on page 3-2 before installing the appliance in the equipment rack.

- Step 1** Locate the equipment rack position you plan to install the appliance into.
- Step 2** Verify that there are no obstructions and ensure that the equipment rack is stabilized.
- Step 3** Position the appliance in the equipment rack, lining up the bracket holes on the appliance with the holes on the rack, and secure it with two 10-32 x 1/2-inch rack screws (each side). You need two people to install the appliance in the rack—one person to hold the appliance and one person to secure it to the rack.

**Note**

The vertical spacing for the equipment rack is at least 1.75 inches (4.44 cm), with mounting holes spaced 1.5 inches (3.81 cm) apart.

- Step 4** Tighten the screws using a Number 2 Phillips screwdriver (each side).

2-Post Rack-Mount Hardware Kit

Figure 3-1 shows the bracket and screws that you need to install the Cisco ADE 2130 and 2140 Series appliance in a 2-post rack. Table 3-1 describes the contents of the rack-mount hardware kit, Cisco part number CADE-2U-BRACKETS.

Figure 3-1 2-Post Rack-Mount Kit

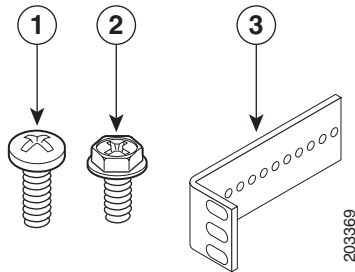

Table 3-1 2-Post Rack-Mount Kit

Item No.	Description	Quantity
1	Rack screw, 10-32 x 1/2-inch (1.27 cm)	4
2	Screw, hex head	6
3	L bracket	2

Mid-Mounting in a 2-Post Rack

This section contains the following topics:

- [Attaching the L Brackets to the Appliance](#), page 3-5
- [Installing the Appliance in the Rack](#), page 3-6

Attaching the L Brackets to the Appliance

To attach the brackets to the appliance:

- Step 1** Place an L bracket (see [Figure 3-2](#)) along one side of the appliance in the mid-mount position (holes 4, 5, and 6 on the appliance).

Figure 3-2 Attaching the L Bracket

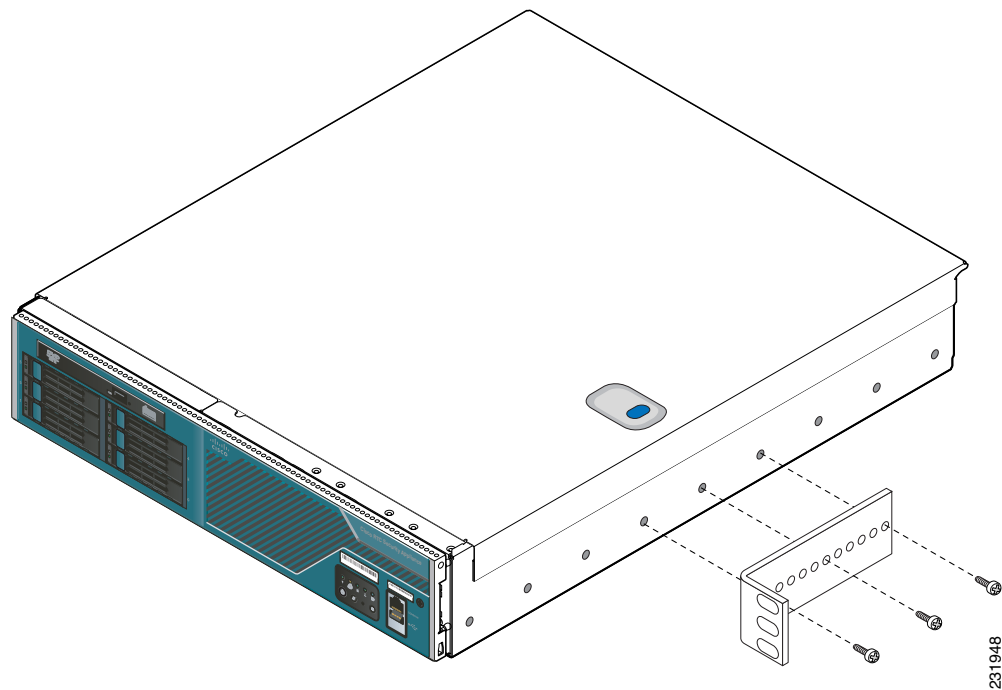

- Step 2** Insert the hex head screws (see [Figure 3-2](#)) and fasten the L bracket to the appliance using a Number 2 Phillips screwdriver.
- Step 3** Repeat Steps 1 and 2 for the other L bracket.
- Step 4** You are now ready to install the appliance into the 2-post rack.

Proceed to the next section, “[Installing the Appliance in the Rack](#),” to continue the installation.

Installing the Appliance in the Rack



Caution

Lifting the appliance and attaching it to the rack is a two-person job. If needed, use an appropriate lifting device. A fully loaded Cisco ADE 2130 and 2140 Series appliance weighs approximately 51.5 lb (23.4 kg).

Before you begin, check the 10-32 x 1/2-inch screws that are included in the 2-post rack-mount kit (see [Table 3-1 on page 3-4](#)) to see if they are the correct size for your rack. If not, obtain the correct screws to use in the procedure where “rack screws” are required.

To mount the appliance in the rack:

-
- Step 1** Locate one person at the front of the rack and one at the rear.
 - Step 2** Position an L bracket on the front side of the center post (see [Figure 3-3](#)).

Figure 3-3 Attaching an L Bracket to a Center Post

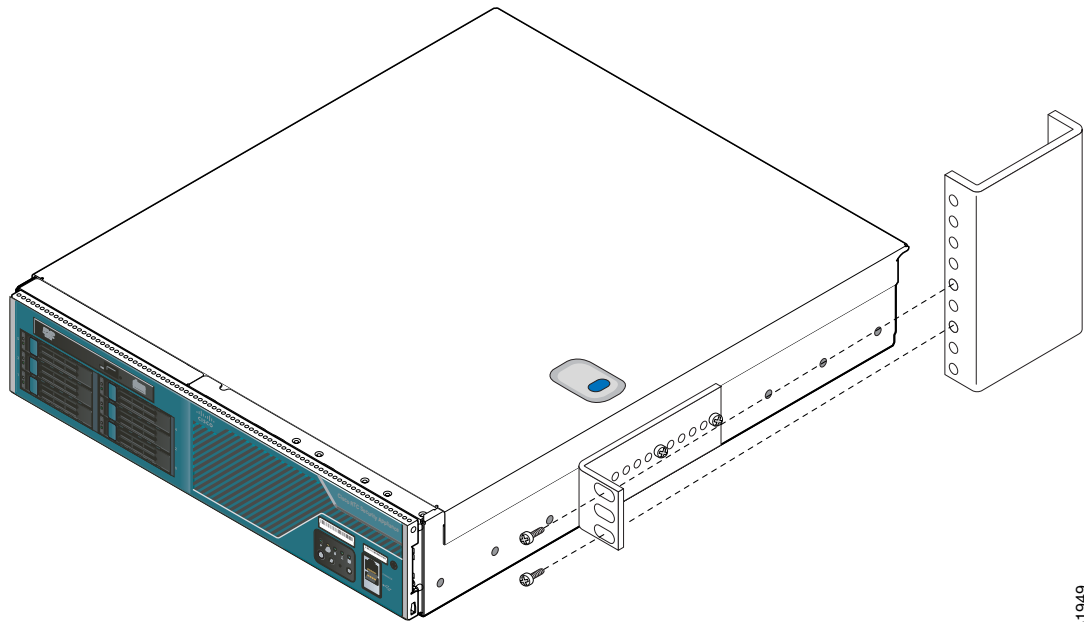

231949

- Step 3** Attach the L bracket to the center post using the 10-32 x 1/2-inch rack screws (see [Figure 3-3](#)). Do not fully tighten the screws at this time.
 - Step 4** Repeat Steps 2 and 3 for the other L bracket.
 - Step 5** Tighten all the 10-32 x 1.2-inch rack screws on both sides of the rack.
-

Mounting the Cisco ADE 2130 and 2140 Series Appliance in a 4-Post Rack



Warning

When the appliance is installed in a rack and is fully extended on its slide rail, it is possible for the rack to become unstable and tip over, which could cause serious injury. To eliminate the risk of rack instability from extending the rail or in the event of an earthquake, you should affix the rack to the floor.

This section contains the following topics:

- [4-Post Rack-Mount Hardware Kit, page 3-7](#)
- [Attaching the Inner Slide Rails to the Appliance, page 3-8](#)
- [Attaching the Outer Slide Rails to the Rack, page 3-9](#)
- [Installing the Appliance into the Rack, page 3-9](#)

4-Post Rack-Mount Hardware Kit

Figure 3-4 shows the rails and brackets that you need to install the Cisco ADE 2130 and 2140 Series appliance in a 4-post rack. Figure 3-5 and Table 3-2 on page 3-8 describes the contents of the rack-mount hardware kit, Cisco part number CADE-2U-RAILS.

Figure 3-4 4-post Rails and Brackets

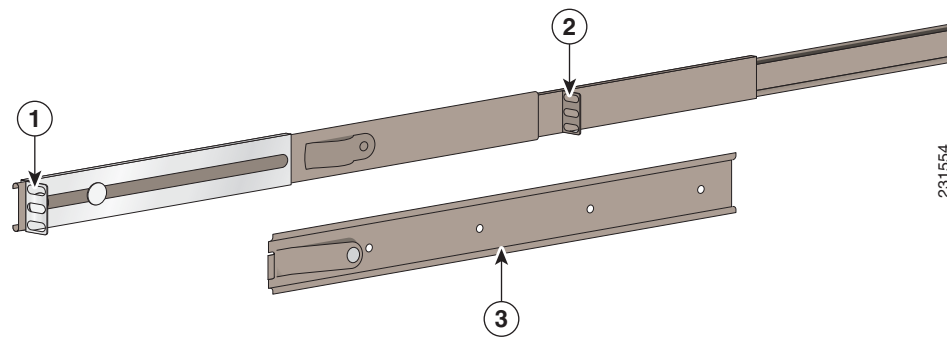

1	Rear-mounting bracket of outer slide rail	3	Inner slide rail
2	Front-mounting bracket of outer slide rail		

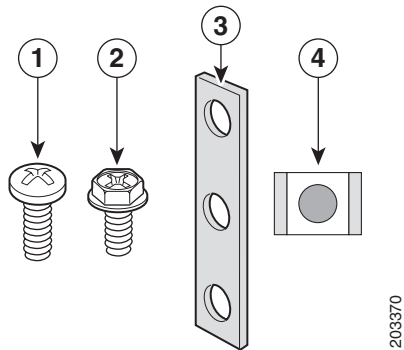
Figure 3-5 4-Post Rack-Mount Hardware Kit**Table 3-2** 4-Post Rack-Mount Hardware Kit

Item No.	Description	Quantity
1	Rack screw, 10-32 x 1/2-inch (1.27 cm)	12
2	Screw, 8-32 x 3/8-inch (.95 cm)	8
3	Nut bar ¹	4
4	Cage nut, 10-32 x 3/8-inch (.95 cm) ²	12
—	Screw, 6-32 x 1/4-inch (.63 cm) ³	8

1. Nut bar used in unthreaded round-hole racks or used over the cage nuts for square-hole racks.
2. Cage nuts are used only when mounting in square-hole racks.
3. Not shown in [Figure 3-5](#). Depending on rack type, can be used in place of 8-32 x 3/8-inch screws.

Attaching the Inner Slide Rails to the Appliance

To install the Cisco ADE 2130 and 2140 Series appliance into the slide rails:

- Step 1** Align the inner slide rail holes with the horizontal holes on the side of the appliance beginning with the second hole. The release spring on the inner slide rail must point toward the rear of the appliance and face away from the appliance chassis. (See [Figure 3-6](#).)

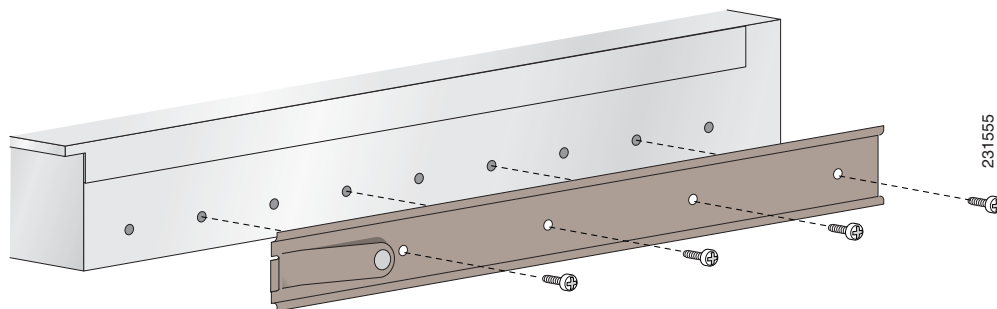
Figure 3-6 Aligning the Inner Slide Rail with the Mounting Studs

- Step 2** Attach the inner slide rail to the appliance with the 8-32 x 3/8-inch screws.

- Step 3** Repeat Steps 1 through 2 for the other inner slide rail and appliance chassis bracket.
You are now ready to install the appliance into the 4-post rack.
-

Proceed to the next section, “[Attaching the Outer Slide Rails to the Rack](#),” to continue the installation.

Attaching the Outer Slide Rails to the Rack

**Caution**

Lifting the appliance and attaching it to the rack is a two-person job. If needed, use an appropriate lifting device. A fully loaded Cisco ADE 2130 and 2140 Series appliance weighs approximately 51.5 lb (23.4 kg).

**Note**

This procedure describes the installation of the outer slide rails to a 4-post threaded-hole rack. If your 4-post rack uses rectangular holes, ensure that you have the proper adapters in place to secure the slide rails to the posts.

To attach the outer slide rails to the rack:

- Step 1** Determine the position on the rack where you want to mount the appliance.
- Step 2** Position the rear-mounting bracket on the outer side of the rear rack post and attach with the 10-32 x 1/2-inch rack screws.
- Step 3** Align the center end of the outer slide rail to the corresponding hole on the front rack post.
- Step 4** Attach the front-mounting bracket of the outer slide rail to the corresponding holes on the front rack post with the 10-32 x 1/2-inch rack screws.
- Step 5** Repeat Steps 2 through 4 for the other outer slide rail.
-

Proceed to the next section, “[Installing the Appliance into the Rack](#),” to continue the installation.

Installing the Appliance into the Rack

**Caution**

If you mount the outer slide rails in holes that are not vertically aligned from front to back, you might damage the slide rails and your mounting might not be secure.

To install the appliance into the rack:

- Step 1** Extend the inner slide rail until it locks into place.
- Step 2** Position the appliance so that the rear end of the inner slide rail aligns with the front end of the outer slide rails.
- Step 3** Slide the appliance into the rack.

You may need to press on the release spring. (See location 1 in [Figure 3-7](#).)

Figure 3-7 Installing Appliance into Rack

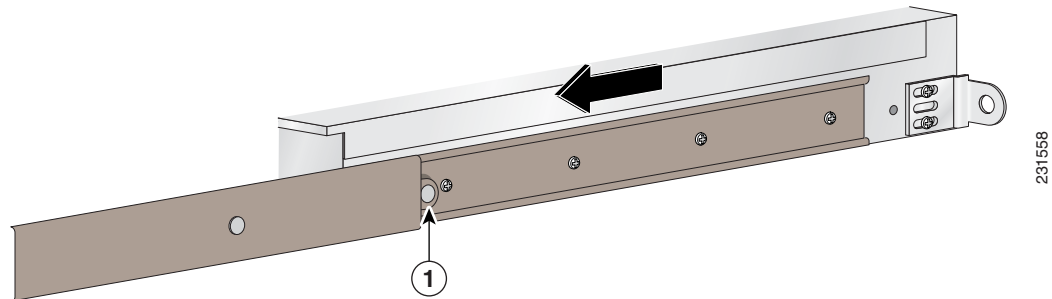

1	Release spring
----------	----------------

Step 4 Slide the appliance until the release spring clicks into place, then push the appliance until the rack-mounting ear meets the front rack posts. (See location 1 in [Figure 3-8](#) on page 3-10.)

Figure 3-8 Sliding Appliance into Rack

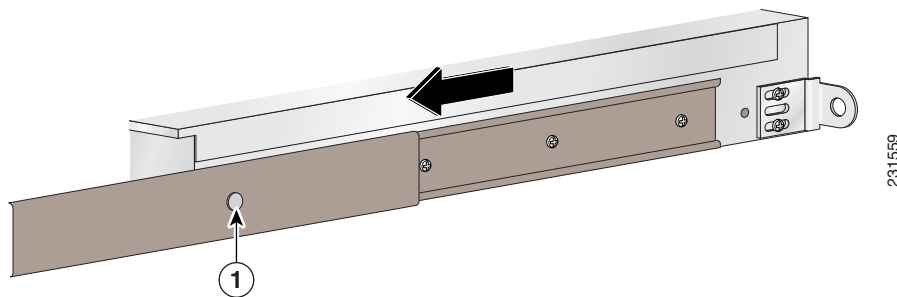

Step 5 (Optional) For extra security, you can attach a third 10-32 x 1/2-inch rack screw from the center of the rack-mounting ear into the front rack post. (See location 1 in [Figure 3-9](#).)

Figure 3-9 Securing the Appliance to the Front Rack Posts

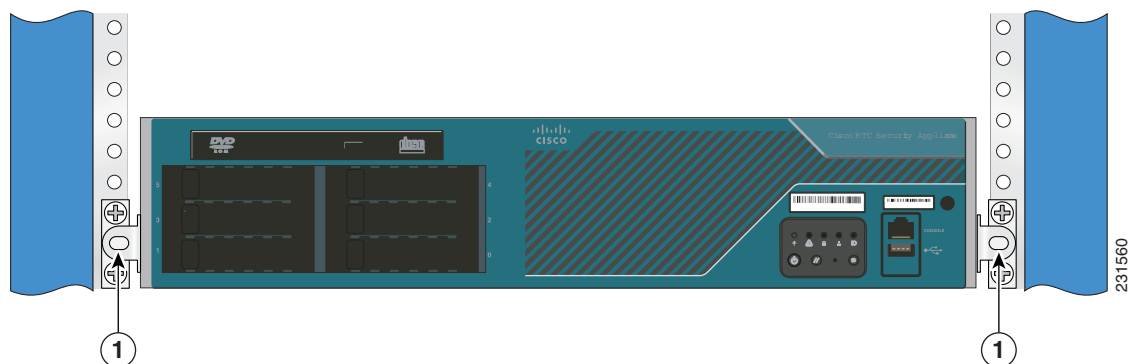

1	Rack screw (10-32 x 1/2 inch)
---	-------------------------------

Proceed to the next section, “[Cisco ADE 2130 and 2140 Series Appliance Power](#),” to continue the installation.

Cisco ADE 2130 and 2140 Series Appliance Power

The Cisco ADE 2130 and 2140 Series appliance has the capability of using either an AC power supply or a DC power supply.



Caution

To ensure proper cooling if only one power supply is installed, the power supply must be in the right-hand slot and the power supply blank filler panel must be in the left-hand slot. (See [Figure 4-10 on page 4-20](#).)



Caution

If the DC power supply is used, ensure that the appliance is properly grounded.



Warning

This equipment must be grounded. Never defeat the ground conductor or operate the equipment in the absence of a suitably installed ground conductor. Contact the appropriate electrical inspection authority or an electrician if you are uncertain that suitable grounding is available. Statement 1024



Warning

This product relies on the building's installation for short-circuit (overcurrent) protection. Ensure that the protective device is rated not greater than: 10 Amps Statement 1005



Warning

Before working on a system that has an on/off switch, turn OFF the power and unplug the power cord. Statement 1



Warning

Do not touch the power supply when the power cord is connected. For systems with a power switch, line voltages are present within the power supply even when the power switch is off and the power cord is connected. For systems without a power switch, line voltages are present within the power supply when the power cord is connected. Statement 4



Warning

Never install an AC power module and a DC power module in the same chassis. Statement 1050



Warning

This unit might have more than one power supply connection. All connections must be removed to de-energize the unit. Statement 1028

This section contains the following topics:

- [Connecting the Appliance AC Power, page 3-12](#)
- [Connecting the Appliance DC Power and Ground, page 3-13](#)

Connecting the Appliance AC Power

When installing the appliance, use the provided AC power cord.

The AC power cord is considered the primary disconnect for the appliance and must be readily accessible when installed. If the appliance power cord is not readily accessible for disconnection then you must install an AC power disconnect for the entire rack. This disconnect must be readily accessible, and it must be properly labeled as the controlling power to the entire rack, not just to the appliance.

Power Connections

To connect the AC power cord to the Cisco ADE 2130 and 2140 Series appliance:

**Caution**

If only one power supply is installed, it must be in the right-hand slot and a power supply blank filler panel must be installed in the left-hand slot to ensure proper cooling. (See location 5 in [Figure 1-5 on page 1-9](#).)

Step 1

Review the information in the “[Safety Warnings](#)” section on page x and the “[Safety Guidelines](#)” section on page 2-2.

**Warning**

This equipment must be grounded. Never defeat the ground conductor or operate the equipment in the absence of a suitably installed ground conductor. Contact the appropriate electrical inspection authority or an electrician if you are uncertain that suitable grounding is available. Statement 1024

Step 2

Plug the AC power cord into the AC power input connector at the rear of the appliance. (See location 5 in [Figure 1-5 on page 1-9](#).)

Step 3

Connect the other end of the power cord to a power source at your site.

Step 4

If you are installing a second redundant AC power supply, repeat Steps 1 and 3 for the second power supply.

Step 5

After confirming that all installation steps are complete, continue with the installation of the network and console cables. (See “[Connecting the Network and Console Cables](#)” section on page 3-18.)

**Caution**

Do not power on the unit, yet.

Proceed to the next section, “[Grounding the Rack](#),” to continue the installation.

Grounding the Rack

To avoid the potential for an electrical shock, you must include a third wire safety ground conductor with the rack installation. If the appliance power cord is plugged into an AC outlet that is part of the rack, then you must provide proper grounding for the rack itself. If the appliance power cord is plugged into a wall outlet, the safety ground conductor in the power cord provides proper grounding only for the appliance. You must provide additional, proper grounding for the rack.

Connecting the Appliance DC Power and Ground

Before you can connect DC power to the Cisco ADE 2130 and 2140 Series appliance, you must provide an adequate chassis ground (earth) to your appliance.

To avoid the potential for an electrical shock, you must connect an earth ground conductor to the appliance. The earth ground conductor must be connected to a 10-to-14 AWG copper wire to the earth ground studs on the rear of the appliance (see location 3 in [Figure 1-5 on page 1-9](#)). The ground

conductor should be connected to the appliance studs with a closed two-hole crimp terminal. The ground conductor provides proper grounding only for the appliance. You must provide additional, proper grounding for the rack.

Grounding Connections

To ensure the appliance chassis ground connection is adequate, you will need the following parts and tools:

- 10-to-14 AWG copper ground wire (insulated or noninsulated)
- Wire-stripping tool for stripping both 10- to 14-AWG copper ground wire
- Crimping tool as specified by the ground lug manufacturer
- Torque wrench



Caution

Before making connections to the Cisco ADE 2130 and 2140 Series appliance, ensure that you disconnect the power at the circuit breaker. Otherwise severe injury or damage to the appliance may result.



Warning

This equipment must be grounded. Never defeat the ground conductor or operate the equipment in the absence of a suitably installed ground conductor. Contact the appropriate electrical inspection authority or an electrician if you are uncertain that suitable grounding is available. Statement 1024



Warning

Use copper conductors only. Statement 1025



Warning

When installing the unit, the ground connection must always be made first and disconnected last. Statement 42

To ground the Cisco ADE 2130 and 2140 Series appliance:

- Step 1** Locate the two 10-32 ground studs on the appliance rear panel. (See location 3 in [Figure 1-5 on page 1-9](#).)
- Step 2** Remove the ground-lug nuts from the studs.
- Step 3** Set the nuts aside.
- Step 4** If your ground wire is insulated, use a wire-stripping tool to strip the 10-AWG ground wire for the ground lug. (See [Figure 3-10](#).)

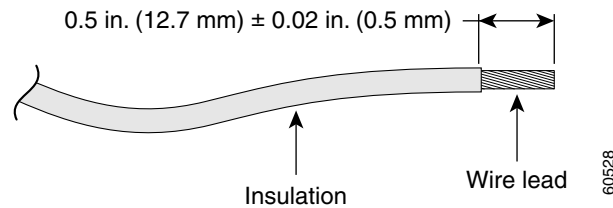
Figure 3-10 Stripping the Ground Wire

- Step 5** Slide the open end of a single 90° standard barrel, two-hole ground lug with 5/8-inch pitch over the exposed area of the 10-AWG wire.
- Step 6** Using a crimping tool (as specified by the ground lug manufacturer), crimp the ground lug to the 10-AWG wire. (See [Figure 3-11](#).)

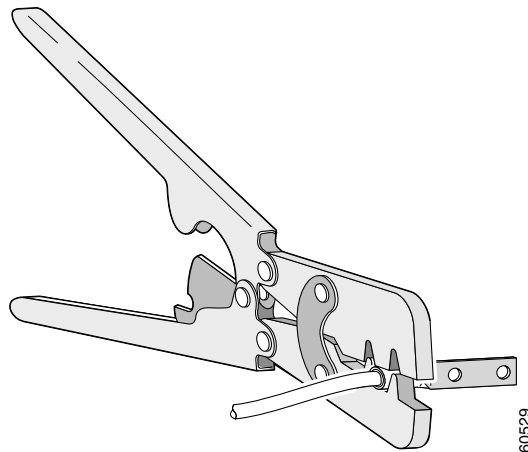
Figure 3-11 Crimping a Ground Lug onto the Ground Wire

- Step 7** Use the two nuts that were installed on the ground studs to attach the ground lug and wire assembly to the two ground studs on the rear of the appliance.
- Step 8** Use a torque wrench to tighten each nut to 10 in-lb (1.12 N-m) torque.
- Step 9** Connect the other end of the ground wire to a suitable grounding point at your site.

Proceed to the next section, "[Power Connections](#)," to continue the installation.

Power Connections

To ensure the appliance chassis power connection is adequate, you will need the following parts and tools:

- 18-AWG copper wire for the power cord
- Wire-stripping tool for stripping the 18-AWG copper wire
- Number 2 Phillips screwdriver

**Warning**

Before performing any of the following procedures, ensure that power is removed from the DC circuit. Statement 1003

**Warning**

Use copper conductors only. Statement 1025

**Warning**

When stranded wiring is required, use approved wiring terminations, such as closed loop or spade-type with upturned lugs. These terminations should be appropriate size for the wires and should clamp both the insulation and conductor. Statement 1002

**Warning**

Connect the unit only to DC power source that complies with the safety extra-low voltage (SELV) requirements in IEC 60950 based standards. Statement 1033

**Warning**

This product requires short-circuit (overcurrent) protection, to be provided as part of a building installation. Install only in accordance with national and local wiring regulations. Statement 1045

**Warning**

This unit might have more than one power supply connection. All connections must be removed to de-energize the unit. Statement 1028

**Note**

The installation must comply with the 2002 National Electric Code (NEC) and other applicable codes.

Wiring the DC-Input Power Source

**Warning**

Hazardous voltage or energy may be present on DC power terminals. Always replace cover when terminals are not in service. Be sure uninsulated conductors are not accessible when cover is in place. Statement 1075

**Warning**

This product relies on the building's installation for short-circuit (overcurrent) protection. Ensure that the protective device is rated not greater than: 10 A minimum, 60 VDC. Statement 1005

To connect the DC power supply to the Cisco ADE 2130 and 2140 Series appliance:

Step 1

Ensure that the appliance (earth) ground connection has been made by following the instructions in the [“Grounding Connections”](#) section on page 3-14.

**Warning**

This equipment must be grounded. Never defeat the ground conductor or operate the equipment in the absence of a suitably installed ground conductor. Contact the appropriate electrical inspection authority or an electrician if you are uncertain that suitable grounding is available. Statement 1024

**Warning****Before performing any of the following procedures, ensure that power is removed from the DC circuit.**

Statement 1003

- Step 2** Turn off the DC power source at the circuit breaker, and tape the circuit breaker in the off position.
- Step 3** On each DC input wire, use a wire stripping tool to strip not more than 0.35 inches (9 mm) of insulation off the end of each wire (see [Figure 3-12](#)). The side on the Molex terminal block connector has a strip gauge for 9 mm.

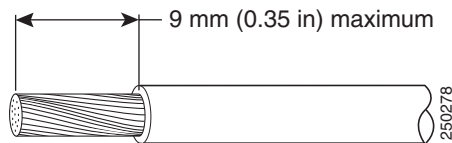
Figure 3-12 Stripping the Power Wire

- Step 4** Grasp the two-pin Molex terminal block and remove it from its mating connector on the power supply unit. Move the Molex terminal block slightly back and forth horizontally to remove it from its mating connector.
- Step 5** Connect the two DC-input wires. Slide open the top of the connector to reveal the screw holes. Insert a Number 2 Phillips screwdriver into the rectangular hole directly above the connector, push the wire fully into the connector, and tighten the screw to 24 in-lb (2.7 N-m) torque with the screwdriver. The wires should be connected in the following order:
- Connect the return (reference) wire to the positive (+) terminal on the terminal block.
 - Connect the -48-V wire to the negative (-) terminal on the terminal block.

**Note**

The color coding of the source DC power wire leads depends on the color coding of the site DC power source. Typically, green or green and yellow indicates that the wire is a ground wire. Because there is no color code standard for the source DC wiring, you must ensure that the power wires are connected to the DC-input power supply terminal block in the proper positive (+) and negative (-) polarity.

In some cases, the source DC wire leads might have a positive (+) or negative (-) label. This is a relatively safe indication of the polarity, but you must verify the polarity by measuring the voltage between the DC wire leads. When taking the measurement, the positive (+) lead and negative (-) lead must always match the positive (+) and negative (-) labels on the DC power supply.

**Caution**

No uninsulated part of the DC-input wire should be exposed.

- Step 6** After the two input wires are connected to the Molex terminal block, plug the Molex terminal block connector into the power connector located on the rear right-hand side of the appliance. (See location 5 in [Figure 1-5](#) on [page 1-9](#).)
- Step 7** Connect the DC power input wires to the DC power source.
- Step 8** If there is a second DC power supply, repeat Steps 3 to 7.
- Step 9** After confirming that all installation steps are complete, continue with the installation of the network and console cables. (See “[Connecting the Network and Console Cables](#)” section on [page 3-18](#).)

**Caution**

Do not power on the unit, yet.

**Warning**

An exposed wire lead from a DC-input power source can conduct harmful levels of electricity. Be sure that no exposed portion of the DC-input power source wire extends from the terminal block plug.

Statement 122

**Warning**

Secure all power cabling when installing this unit to avoid disturbing field-wiring connections.

Statement 38

Proceed to the next section, “[Connecting the Network and Console Cables](#),” to continue the installation.

Connecting the Network and Console Cables

This section describes how to connect your Cisco ADE 2130 and 2140 Series appliance to the network and the appliance console. It includes the following sections:

- [Connecting the Network Interface](#), page 3-18
- [Connecting the Console](#), page 3-19
- [Cable Management](#), page 3-19

Connecting the Network Interface

**Warning**

Do not work on the system or connect or disconnect cables during periods of lightning activity.

Statement 1001

This section describes how to connect the Cisco ADE 2130 and 2140 Series appliance network interface connector (NIC) port.

The RJ-45 port supports standard straight-through and crossover Category 5 unshielded twisted-pair (UTP) cables. Cisco does supply one Category 5 UTP cable (yellow). If more UTP cables are needed, these cables are available commercially. (See [Table 1-9 on page 1-12](#) for information about Category 3, 4, 5, 5e, and 6 cables.)

To connect the cable to the appliance network interface connector (NIC) port:

-
- Step 1** Confirm that the appliance is turned off.
 - Step 2** Connect one end of the cable to the NIC port on the appliance. (For cable pinouts, see the “[Ethernet Port Connector](#)” section on page 1-12.)
 - Step 3** Connect the other end to a hub or switch in your network.
-

Proceed to the next section, “[Connecting the Console](#),” to continue the installation.

Connecting the Console



Do not work on the system or connect or disconnect cables during periods of lightning activity.
Statement 1001

Your Cisco ADE 2130 and 2140 Series appliance has an RJ-45 serial (console) port on the front or back of the appliance for connecting a console terminal to your appliance. Only one serial (console) port can be used at a time because they are shared. (See the “[Serial \(Console\) Port](#)” section on page 1-12 for more information.)

To connect a terminal or a PC running terminal-emulation software to the console port on the Cisco ADE 2130 and 2140 Series appliance:

-
- Step 1** Connect the terminal using a rollover cable (provided) to the console port. For cable pinouts, see the “[Serial \(Console\) Port Connector](#)” section on page 1-13.
 - Step 2** Configure your terminal or terminal-emulation software for 9600 baud, 8 data bits, no parity, 1 stop bit, and no hardware flow control.
-

Cable Management

Cable management is the most visual aspect of your appliance setup. However, cable management is often overlooked because it can be time consuming.

Equipment racks and enclosures house more equipment today than ever before. This growth has increased the need for organized cable management both inside and outside the rack. Poor cable management not only leads to damaged cables or increased time for adding or changing out cables, but also blocks critical airflow or access. These problems can lead to inefficiencies in the performance of your equipment or even downtime.

There are many solutions to address cable management. They can range from simple cable management rings, to cable management brackets, to vertical or horizontal organizers, to troughs and ladders.

All Cisco ADE 2130 and 2140 Series appliance cables should be properly dressed so as not to interfere with each other or other pieces of equipment. Use local practices to ensure that the cables attached to your appliance are properly dressed.

Proceed to the next section, “[Powering Up the Cisco ADE 2130 and 2140 Series Appliance](#),” to continue the installation.

Powering Up the Cisco ADE 2130 and 2140 Series Appliance



Warning

Do not touch the power supply when the power cord is connected. For systems with a power switch, line voltages are present within the power supply even when the power switch is off and the power cord is connected. For systems without a power switch, line voltages are present within the power supply when the power cord is connected. Statement 4



Warning

This equipment is intended to be grounded. Ensure that the host is connected to earth ground during normal use. Statement 39

This section explains how to power up the appliance. Depending on whether your appliance has AC or DC power supplies, see the appropriate section:

[Power-Up Procedure \(AC Power Supply\), page 3-20](#)

[Power-Up Procedure \(DC Power Supply\), page 3-21](#)



Warning

Never install an AC power module and a DC power module in the same chassis. Statement 1050

Power-Up Procedure (AC Power Supply)

To power up a Cisco ADE 2130 and 2140 Series appliance with an AC power supply and verify its initialization and self-test, follow this procedure. When the procedure is finished, the appliance is ready to configure.

-
- Step 1** Review the information in the [“Safety Guidelines” section on page 2-2](#).
 - Step 2** Before proceeding, if the AC power cord is connected directly into the AC power outlet and because the AC power cord provides its own ground conductor, you only need to ensure that the rack has been properly grounded. (See the [“Connecting the Appliance AC Power” section on page 3-12](#) for more information.)
 - Step 3** Plug the AC power cord into the power cord receptacle at the rear of the appliance. (See location 1 in [Figure 1-5 on page 1-9](#).)
 - Step 4** Connect the other end of the power cord to a power source at your installation site.
 - Step 5** If there is a second AC power supply, repeat Steps 3 and 4 for the second power supply.
 - Step 6** Press the power button on the front of the appliance. (See location 9 in [Figure 3-13 on page 3-21](#).)
The appliance should begin its powerup procedure.
 - Step 7** After the operating system boots up, observe the front-panel LEDs to verify that your system is operating properly. (See [Figure 3-13 on page 3-21](#) and the [“Checking the LEDs” section on page 3-21](#).)
Once the operating system boots, you are ready to initialize the basic software configuration. (See the software installation guide or user guide that shipped with your appliance for proper configuration procedures.)
-

Power-Up Procedure (DC Power Supply)

To power up a Cisco ADE 2130 and 2140 Series appliance with a DC power supply and verify its initialization and self-test, follow this procedure. When the procedure is finished, the appliance is ready to configure.

If a redundant power supply is used, separate DC power sources are needed for each power supply. This allows you to turn off power for one power supply without affecting the power source for the other.

-
- Step 1** Review the information in the [“Safety Guidelines” section on page 2-2](#).
- Step 2** Plug the Molex terminal block connector into the power connector located on the rear right-hand side of the appliance. (See location 1 in [Figure 1-5 on page 1-9](#).)
- Step 3** Connect the DC power input wires to the DC power source at your installation site.
- Step 4** Press the power button on the front of the appliance. (See location 9 in [Figure 3-13 on page 3-21](#).)
The appliance should begin its powerup procedure.
- Step 5** After the operating system boots up, observe the front-panel LEDs to verify that your system is operating properly. (See [Figure 3-13 on page 3-21](#) and the [“Checking the LEDs” section on page 3-21](#).)
Once the operating system boots, you are ready to initialize the basic software configuration. (See the software installation guide or user guide that shipped with your appliance, for proper configuration procedures.)
-

Checking the LEDs

When the Cisco ADE 2130 and 2140 Series appliance is up and running, observe the front-panel LEDs. (See [Figure 3-13](#).)

Figure 3-13 Cisco ADE 2130 and 2140 Series Appliance Front Control Panel

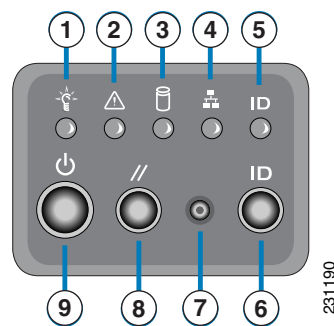

1	Appliance power LED	6	ID control switch (push button)
2	Appliance status LED	7	NMI (nonmaskable interrupt) recessed button ¹
3	Hard disk drive activity LED	8	Reset push button
4	NIC activity (all NICs)	9	Appliance power push button
5	Appliance system ID LED		

1. When pressed, clears the processor allowing the processor to continue to execute the software normally.

The following LEDs provide power, activity, and status information:

ADE 2130 and 2140 Appliance Front-Panel LEDs

- Appliance power, green:
 - On when power is on.
 - Off when power is off or an error condition has been detected in the operating voltages.
- Hard disk activity, green:
 - On when appliance software has booted up, and the appliance is operational.
 - Off when appliance has not yet booted, or an error condition has been detected in the boot process.
- NIC 1 or NIC 2, green:
 - On when packets are transferring
 - Off when no packets are transferring

For more detailed information about the LEDs, see [Appendix A, “Troubleshooting.”](#)

Removing or Replacing the Cisco ADE 2130 and 2140 Series Appliance



Warning

Before working on a system that has an On/Off switch, turn OFF the power and unplug the power cord.
Statement 1



Warning

Ultimate disposal of this product should be handled according to all national laws and regulations.
Statement 1040

To remove a Cisco ADE 2130 and 2140 Series appliance from your network, power it down, disconnect the power cords and network cables, and physically remove the appliance from the rack.

The appliance is in constant communication on your network; thus, when the network notices that the appliance is no longer responding to it, the network stops sending requests to the appliance. This change is transparent to users. If other appliances are attached to the network, the network continues sending requests to the other appliances.

To replace an appliance, remove it from the network. Then, install a new appliance and configure it using the same configuration parameters that you used for the removed appliance.



CHAPTER 4

Installing the Cisco ADE 2130 and 2140 Series Appliance Hardware Options

This chapter provides instructions for installing, replacing, and removing various hardware options in your Cisco ADE 2130 and 2140 Series appliance.

These instructions are intended for technicians who are experienced with installing, replacing, and removing the appliance hardware options. Additionally, site planners, network administrators, and facility maintenance personnel might also find this chapter helpful.

This chapter contains the following sections:

- [Before You Begin, page 4-2](#)
- [Preparing for a Successful Installation, page 4-2](#)
- [Hardware Options, page 4-2](#)
- [Tools and Supplies Needed, page 4-3](#)
- [Beginning the Installation, page 4-3](#)
- [Installing a Hard Drive Tray into the Appliance, page 4-5](#)
- [Removing and Installing the Processor Air Duct, page 4-7](#)
- [Installing and Removing Memory, page 4-9](#)
- [Removing and Installing the PCI Adapter Card, page 4-12](#)
- [Installing or Replacing a Power Supply, page 4-17](#)
- [Completing the Installation, page 4-20](#)

Before You Begin

Before you begin, read the *Regulatory Compliance and Safety Information for the Cisco Application Deployment Engine (ADE) 2130 and 2140 Series Appliance* document that shipped with your appliance.



Warning

Only trained and qualified personnel should be allowed to install, replace, or service this equipment.
Statement 1030



Note

The order of installation or uninstallation tasks may vary. This chapter lists the tasks in the order that constitutes best practices for the installation or uninstallation.

The directions *left* and *right* in this chapter are synonymous with the *installer's left* and *right*. They refer to the installation or uninstallation as you face the appliance from the front.

Preparing for a Successful Installation

The installation and uninstallation of the hardware options for the Cisco ADE 2130 and 2140 Series appliance involve many steps, most of which must be done in the order in which they are presented here. Each section explains one associated group of tasks upon which the next section's tasks are built.

Hardware Options

Table 4-1 describes the hardware options available for the Cisco ADE 2130 and 2140 Series appliance.

Table 4-1 Cisco ADE 2130 and 2140 Series Appliance Hardware Options

Description	Cisco Spare Part Number
1-GB RAM	CADE-RAM-15EU=
2-GB RAM	CADE-RAM-25EF=
250-GB Serial ATA ¹ Hard Disk Drive (HDD)	CADE-HDD-T372050=
147-GB SAS ² Hard Disk Drive (HDD)	CADE-HDD-A2100147=
DVD-ROM drive	800-29866-01
AC power supply	CADE-2U-AC-PSU=
DC power supply	CADE-2U-DC-PSU=
Cisco ADE Accelerator Card – Pro-1000/MT Dual-Port GigE NIC	CADE-EXP-1XN4FR=
Cisco ADE Accelerator Card – w/4 GigE RJ-45 ports	CADE-EXP-NXN4FR=
Cisco ADE Accelerator Card – Mod card (requires small form factor pluggable module [SFP])	CADE-EXP-NXN4FM=
Cisco ADE Accelerator Card – 2 x 2-GigE ports	CADE-EXP-NXN2FM=

Table 4-1 Cisco ADE 2130 and 2140 Series Appliance Hardware Options (continued)

Description	Cisco Spare Part Number
Cisco ADE Accelerator Card – 10 Gb/s (requires 10-Gb small form factor pluggable module [XFP] and memory)	CADE-EXP-NXN2FG=
Cisco ADE XFP – long reach	CADE-XO-NX10GSLR1=
Cisco ADE XFP – short reach	CADE-XO-NX10GMLR1=
Cisco ADE – 2-GB onboard memory for 10-GigE card	CADE-XO-NRDR22GB1=

1. Serial ATA = Serial Advanced Technology Attachment.
2. SAS = Serial Attached SCSI (Small Computer System Interface).

Tools and Supplies Needed

You need the following tools and equipment to install, replace, and remove the hardware options:

- Number 1 and 2 Phillips screwdrivers
- ESD or antistatic wrist strap and conductive foam pad or mat (recommended)

Beginning the Installation

To begin the installation, you must remove the front bezel and appliance top cover. Before removing the cover, power down the appliance, and unplug all external cables and the AC power cable or DC power wires.

Removing the Cover



Warning

Before performing any of the following procedures, ensure that power is removed from the DC circuit.
Statement 1003



Warning

Before working on a chassis or working near power supplies, unplug the power cord on AC units.
Statement 246



Note

A nonskid surface or a stop behind the appliance may be needed to prevent the appliance from sliding on your work surface.

To remove the cover:

Step 1

Review the information in the [“Safety Warnings”](#) section on page x and the [“Safety Guidelines”](#) section on page 2-2.

- Step 2** Power down the appliance and all external devices. Disconnect the AC power cord or DC power source and all external cables.
- Step 3** Attach the antistatic wrist strap to your wrist and connect its cord to the ESD socket on the top, left-hand side on the front of the appliance.
- Step 4** Remove the shipping screw, if present.
- Step 5** While pushing in and holding the blue button at the top of the appliance chassis (see location 1 in Figure 4-1), slide the top cover back until it stops.

Figure 4-1 Removing the Cisco ADE 2130 and 2140 Series Appliance Cover

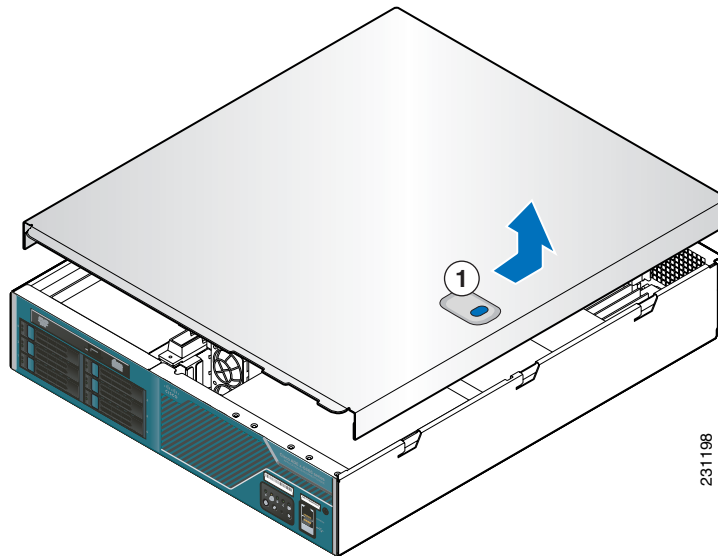

1	Blue button
----------	-------------

- Step 6** Lift the cover straight up to remove it from the appliance.



Caution

For proper cooling and airflow, replace the cover before turning on the appliance. Operating the appliance for extended periods (over 30 minutes) with the cover removed might damage the appliance components.



Warning

The covers are an integral part of the safety design of the product. Do not operate the unit without the covers installed. Statement 1077

Removing the Front Bezel

**Note**

The following procedures assume your Cisco ADE 2130 and 2140 Series appliance came shipped with the front bezel installed.

Remove the front bezel to:

- install or remove hard drives or the optional DVD-ROM drive
- access the front-panel serial (console) port and USB ports
- observe the individual hard disk drive (HDD) activity and fault LEDs

**Note**

The appliance does not need to be powered down to remove the front bezel.

To remove the front bezel:

- Step 1** Unfasten the bezel retention screw on the right side of the appliance with a Number 2 Phillips screwdriver.
- Step 2** Rotate the bezel outward and detach.

To install the front bezel:

- Step 1** Align the four tabs on the left of the bezel with the slots in the front panel and then rotate the free end of the bezel to the closed position.
- Step 2** Snap the front bezel into place and tighten the screw at the right side of the bezel.

Installing a Hard Drive Tray into the Appliance

**Note**

The hard drives are hot-swappable. Before removing or replacing a hard drive, you do not need to take the Cisco ADE 2130 and 2140 Series appliance out of service.

Up to six drives can be installed. The hard drive bay is at the left side of the appliance chassis, underneath the DVD-ROM drive. The hard drive trays in the drive bay are labeled 1, 3, and 5 on the left side of the bay and 0, 2, and 4 on the right side of the bay (see [Figure 4-2 on page 4-6](#)). The drives need to be installed in a specific order; that is, drive 0 must be installed before drive 1, drive 1 before drive 2, and so on.

**Caution**

If you install fewer than six hard drives, the empty bays must have drive trays with baffles in them to maintain proper appliance cooling.

To install a hard drive into the appliance:

-
- Step 1** Inspect the new drive for any signs of damage.
 - Step 2** Review the information in the “[Safety Warnings](#)” section on page x and the “[Safety Guidelines](#)” section on page 2-2.
 - Step 3** Power down the appliance and all external devices. Disconnect the AC power cord or DC power source and all external cables.
 - Step 4** Attach the antistatic wrist strap to your wrist and connect its cord to the ESD socket on the top, left-hand side on the front of the appliance.
 - Step 5** Select the drive bay where you want to install the drive.
 - Step 6** Remove the drive tray by pressing the blue button to open the lever and pull the tray out. (See location 1 in [Figure 4-2](#).)

Figure 4-2 Removing the Hard Drive Tray

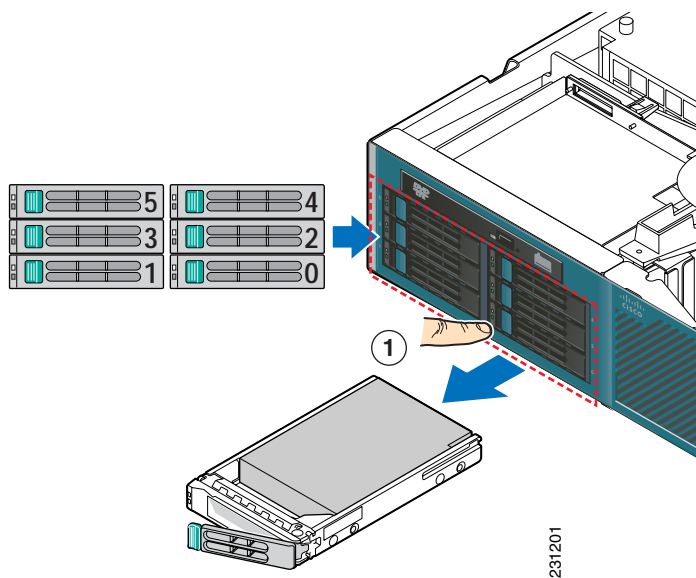

1	Blue button
----------	-------------



Note If fewer than six drives are installed, drive bay 0 must be used first, then drive bay 1, and so forth. The drive tray numbers are shown in [Figure 4-2](#).

- Step 7** If a hard drive is already installed in the hard drive tray, you can remove it by unfastening the four screws that attach it to the drive tray with a Number 2 Phillips screwdriver.
- Step 8** Install the new drive in the drive tray and secure the drive with the four screws with a Number 2 Phillips screwdriver.
- Step 9** To reinstall the drive tray, with the drive tray locking lever open, push the drive tray into the drive bay until it stops. (See location 1 in [Figure 4-3](#) on page 4-7.)

Figure 4-3 Installing the Hard Drive Tray

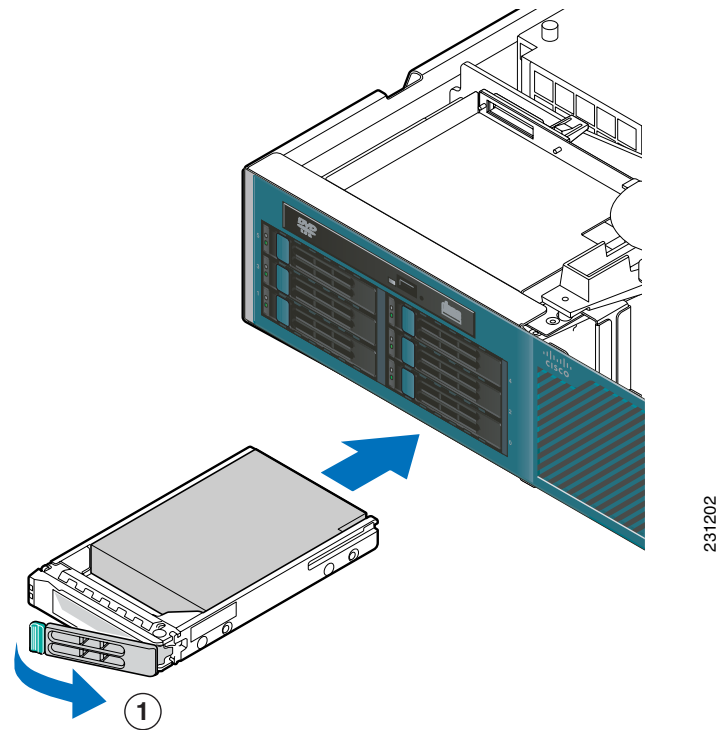

1	Drive tray
----------	------------

Step 10 Press the lever until it snaps shut to secure the drive into the drive bay.

Removing and Installing the Processor Air Duct

This section contains the following topics:

- [Removing the Processor Air Duct, page 4-7](#)
- [Installing the Processor Air Duct, page 4-9](#)

Removing the Processor Air Duct

The air duct must be removed to access the processors and the DIMMs.



The processor air duct is required for proper airflow within the chassis. Be sure the air duct is in place again before installing the appliance cover.

To remove the processor air duct:

- Step 1** Review the information in the “Safety Warnings” section on page x and the “Safety Guidelines” section on page 2-2.
- Step 2** Power down the appliance and all external devices. Disconnect the AC power cord or DC power source and all external cables.
- Step 3** Attach the antistatic wrist strap to your wrist and connect its cord to the ESD socket on the top, left-hand side on the front of the appliance.
- Step 4** Remove the appliance cover. For instructions, see the “Removing the Cover” section on page 4-3.
- Step 5** Slide the duct a few inches (millimeters) toward the rear of the appliance until it stops. (See location 2 in Figure 4-4.)

The front edge will disengage from the front panel. (See location 3 in Figure 4-4.) The metal tab at the rear will release. (See location 4 in Figure 4-4.)

Figure 4-4 Removing the Processor Air Duct

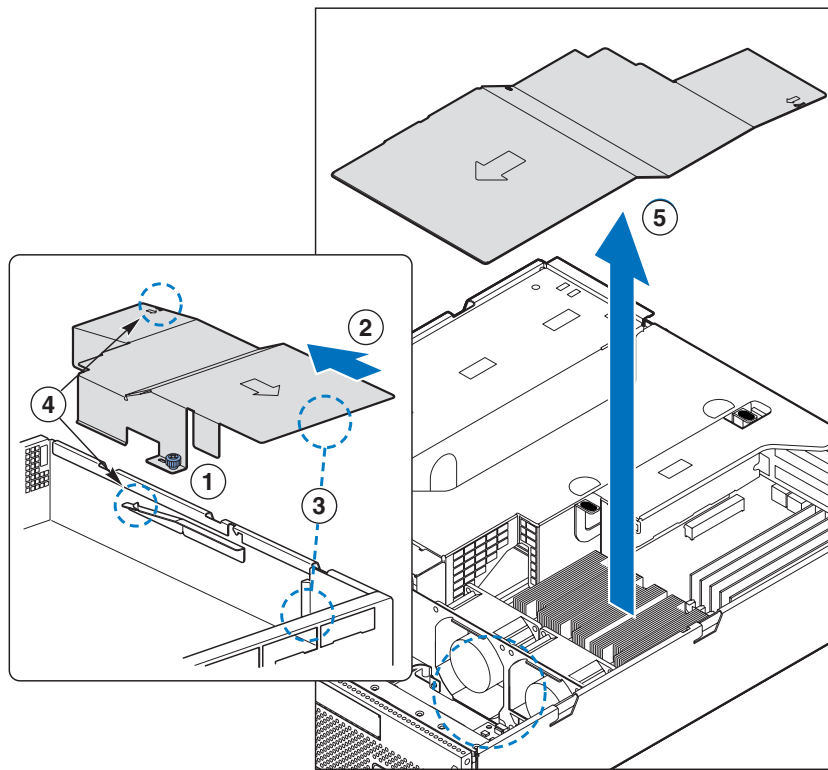

1	Captive fastener	3	Front edge
2	Slide air duct towards rear	4	Metal tab
5	Lift air duct up		

- Step 6** Loosen the captive fastener. (See location 1 in Figure 4-4.)

- Step 7** Lift the air duct straight up and remove it from the appliance chassis. (See location 5 in [Figure 4-4 on page 4-8.](#))
-

Installing the Processor Air Duct

**Caution**

The processor air duct is required for proper airflow within the chassis. Be sure the air duct is in place again before installing the appliance cover.

To install the processor air duct:

- Step 1** Review the information in the [“Safety Warnings” section on page x](#) and the [“Safety Guidelines” section on page 2-2.](#)
- Step 2** Power down the appliance and all external devices. Disconnect the AC power cord or DC power source and all external cables.
- Step 3** Remove the appliance cover. For instructions, see the [“Removing the Cover” section on page 4-3.](#)
- Step 4** Slide the duct forward until it is flush with the front of the appliance and stops.
The front edge will engage at the front panel. (See location 3 in [Figure 4-4 on page 4-8.](#)) The metal tab at the rear will engage. (See location 4 in [Figure 4-4 on page 4-8.](#))
- Step 5** Push the air duct down into the appliance chassis.
- Step 6** Tighten the captive fastener. (See location 1 in [Figure 4-4 on page 4-8.](#))
-

Installing and Removing Memory

This section contains the following topics:

- [Installing DIMMs, page 4-11](#)
- [Removing DIMMs, page 4-12](#)

**Caution**

The memory is *not* hot-swappable. Before removing or replacing any dual in-line memory module (DIMM), you must first take the Cisco ADE 2130 and 2140 Series appliance out of service, turn off the appliance by pressing the power button, and unplug the AC power cord from the appliance or wall outlet or disconnect the DC power source.

**Caution**

When you handle static-sensitive devices, take precautions to avoid damage from static electricity. For more information on handling these devices, see the [“Preventing Electrostatic Discharge Damage” section on page 2-5.](#)

The appliance provides eight DIMM slots across two branches (0 and 1) of four channels, channel A through Channel D. Channel A consists of DIMM slots A1 and A2, Channel B consists of DIMM slots B1 and B2, Channel C consists of DIMM slots C1 and C2, and Channel D consists of DIMM slots D1 and D2. The slots associated with each channel, are located next to each other. A diagram on the logic board near the DIMM slots illustrates the location of the DIMM slots. Each slot accepts 533/667-MHz stacked Double-Data-Rate 2 (DDR2) Error Correction Code (ECC) or non-ECC unbuffered memory.

DIMMs are populated in pairs and are populated in the following DIMM slot order (see [Figure 4-5](#)):

- A1 and B1
- C1 and D1
- A2 and B2
- C2 and D2

Figure 4-5 DIMM Slots

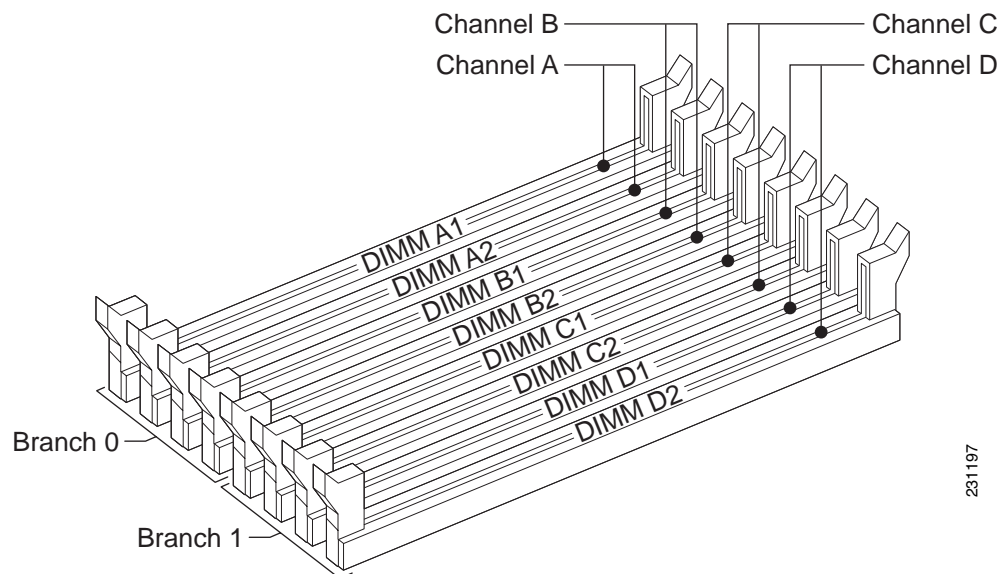

DIMMs within a given pair must be identical with respect to size, speed, and organization. However, DIMM capacities can be different between different DIMM pairs. For example, a valid mixed-DIMM configuration may have:

- 512-MB DIMMs installed in DIMM slots A1 and B1
- 1-GB DIMMs installed in DIMM slots C1 and D1

The following restrictions apply:

- Single-channel mode is supported only with a 512-MB DIMM installed in DIMM slot A1.
- For best performance, the number of DIMMs installed should be balanced across both memory branches. For example, a four-DIMM configuration performs better than a two-DIMM configuration and should be installed in DIMM slots A1, B1, C1, and D1. An eight-DIMM configuration performs better than a six-DIMM configuration.

Installing DIMMs

To install the DIMMs:

- Step 1** Review the information in the “[Safety Warnings](#)” section on page x and the “[Safety Guidelines](#)” section on page 2-2.
- Step 2** Power down the appliance and all external devices. Disconnect the AC power cord or DC power source and all external cables.
- Step 3** Attach the antistatic wrist strap to your wrist and connect its cord to the ESD socket on the top, left-hand side on the front of the appliance.
- Step 4** Remove the appliance cover. For instructions, see the “[Removing the Cover](#)” section on page 4-3.
- Step 5** Locate the DIMM slots. (See [Figure 4-6](#).)

Figure 4-6 Installing DIMMs

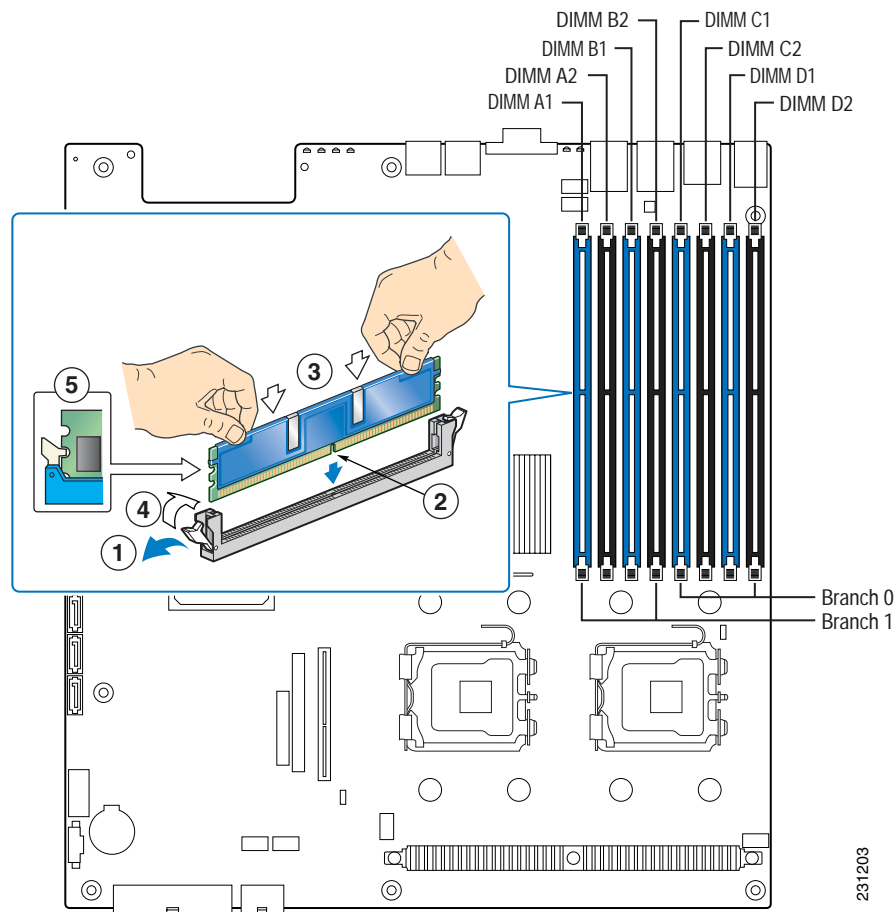

1	Ejector tab (open)	4	Ejector tab (closed)
2	DIMM notch	5	DIMM outside connector edge
3	DIMM top connector edge		

Step 6 Make sure the ejector tabs at both ends of the DIMM slots are pushed outward to the sides (open position). (See location 1 in [Figure 4-6 on page 4-11.](#))

Step 7 Holding the DIMM by the top edges, remove it from its anti-static package.



Caution Do not touch the DIMM connectors. Handle the DIMM only by the edges.

Step 8 Position the DIMM above the slot. Align the notch on the bottom edge of the DIMM with the key in the DIMM slot. (See location 2 in [Figure 4-6 on page 4-11.](#))

Step 9 Insert the bottom edge of the DIMM into the slot. (See location 3 in [Figure 4-6 on page 4-11.](#))

Step 10 When the DIMM is correctly positioned, push down *firmly* on the top edge of the DIMM until the ejector tabs snap into place. (See location 4 in [Figure 4-6 on page 4-11.](#))

Step 11 Install the appliance cover. For instructions, see the “[Installing the Cover](#)” section on page 4-20.

Removing DIMMs

To remove a DIMM:

Step 1 Review the information in the “[Safety Warnings](#)” section on page x and the “[Safety Guidelines](#)” section on page 2-2.

Step 2 Power down the appliance and all external devices. Disconnect the AC power cord or DC power source and all external cables.

Step 3 Attach the antistatic wrist strap to your wrist and connect its cord to the ESD socket on the top, left-hand side on the front of the appliance.

Step 4 Remove the appliance cover. For instructions, see the “[Removing the Cover](#)” section on page 4-3.

Step 5 Locate the DIMM slots. (See [Figure 4-6 on page 4-11.](#))

Step 6 Open the ejector tabs on the DIMM slot by pushing them out to the sides. (See location 1 in [Figure 4-6 on page 4-11.](#))

Step 7 Holding the DIMM by the edges, lift it straight up out of the slot, and store it in an antistatic package.

Step 8 Install the appliance cover. For instructions, see the “[Installing the Cover](#)” section on page 4-20.

Removing and Installing the PCI Adapter Card



Caution The PCI adapter cards are *not* hot-swappable. Before removing or replacing an adapter card, you must first take the Cisco ADE 2130 and 2140 Series appliance out of service, turn off the appliance by pressing the power button, disconnect all external cables, and unplug the AC power cord or DC power source from the appliance.

This section describes how to install a PCI adapter card in the Cisco ADE 2130 and 2140 appliance. Before you install an adapter card, review the following information:

- Your appliance comes with a Peripheral Component Interconnect-Extended (PCI-X) riser card and a PCI Express (PCIe) riser card. These slots are located in the appliance with a PCI riser assembly. (See the “[Removing the PCI Riser Assembly](#)” section on page 4-14, for instructions on how to remove the PCI riser assembly.)
- Locate the documentation that comes with the PCI adapter card and follow those instructions in addition to the instructions in this section.
- The PCI riser assembly must be removed before you can remove, replace, or install a PCI adapter card in the Cisco ADE 2130 and 2140 Series appliance:
 - A PCI-X riser card for full-height, full-length PCI-X adapter cards
 - A PCI Express (PCIe) riser card with two slots for low-profile PCIe adapter cards
- Any PCI-X adapter card can be installed in any PCI-X slot. Only the PCIe x4 adapter card can be installed in a PCIe.
- There are no population rules for installing a single low-profile adapter card in the 2U low-profile riser card; a single adapter card can be installed in either PCI Express slot. Each slot supports only an x4 interface. (See [Table 4-2](#) and [Table 4-3](#) on page 4-13 for full-height and low-profile adapter card configurations, respectively.)

Table 4-2 Full-Height Adapter Card Configurations

Configuration	Bottom Slot	Middle Slot	Top Slot
1 adapter card	PCI-X ¹	—	—
	—	x4 PCIe	—
	—	—	x4 PCIe
2 adapter cards	PCI-X ¹	x4 PCIe	—
	PCI-X ¹	—	x4 PCIe
	—	x4 PCIe	x4 PCIe
3 adapter cards	PCI-X ¹	x4 PCIe	x4 PCIe

1. Up to 133 MHz bus speed.

Table 4-3 Low-Profile Adapter Card Configurations

Configuration	Lower Slot	Upper Slot
1 adapter card	x4 PCIe	—
	—	x4 PCIe
2 adapter cards	x4 PCIe	x4 PCIe

To install an adapter card, you first need to remove the top cover, the processor air duct, and the riser card assembly from the appliance and remove the I/O filler panel from the slot where you will be installing the adapter card. Once the PCI-X or PCIe adapter card is attached to the appropriate riser card connector, this assembly is then plugged back into the connectors on the appliance system board.

This section contains the following topics:

- [Removing the PCI Riser Assembly, page 4-14](#)
- [Removing a PCI Adapter Card, page 4-15](#)

- [Installing a PCI Adapter Card](#), page 4-16
- [Installing the PCI Riser Assembly](#), page 4-17

**Caution**

Before removing or replacing the PCI riser assembly, you must first take the Cisco ADE 2130 and 2140 Series appliance out of service, turn off the appliance by pressing the power button, disconnect any external cables, and unplug the AC power cord or DC power source from the appliance.

Removing the PCI Riser Assembly

**Warning**

During this procedure, wear grounding wrist straps to avoid ESD damage to the card. Do not directly touch the backplane with your hand or any metal tool, or you could shock yourself. Statement 94

To remove the PCI riser assembly:

- Step 1** Review the information in the “[Safety Warnings](#)” section on page x and the “[Safety Guidelines](#)” section on page 2-2.
- Step 2** Power down the appliance and all external devices. Disconnect the AC power cord or DC power source and all external cables.
- Step 3** Attach the antistatic wrist strap to your wrist and connect its cord to the ESD socket on the top, left-hand side on the front of the appliance.
- Step 4** Remove the appliance cover. For instructions, see the “[Removing the Cover](#)” section on page 4-3.
- Step 5** Disconnect any cables attached to any adapter cards.
- Step 6** Lift the riser assembly up to remove it. (See location 1 in [Figure 4-7](#).)

Figure 4-7 Removing the PCI Riser Assembly from the Appliance

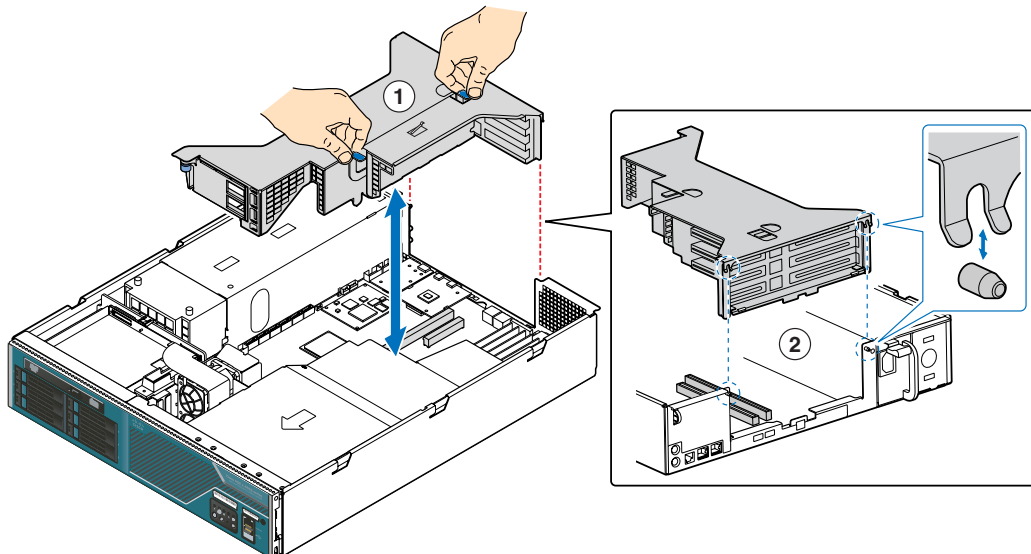

231196

1	PCI riser assembly
----------	--------------------

2	Pins
----------	------

- Step 7** Note the location of the pins on each side of the rear-panel opening where the riser adapter card assembly bracket attaches. (See location 2 in [Figure 4-7 on page 4-14](#)).
- Step 8** To remove a PCI adapter card, go to the [“Removing a PCI Adapter Card”](#) section on this page.
- Step 9** If you removed the PCI riser assembly for another procedure, continue with that procedure.
- Step 10** If you have other hardware options to install, do so now; otherwise, go to the [“Completing the Installation”](#) section on page 4-20.

Removing a PCI Adapter Card

To remove a PCI adapter card:

- Step 1** Review the information in the [“Safety Warnings”](#) section on page x and the [“Safety Guidelines”](#) section on page 2-2.
- Step 2** Power down the appliance and all external devices. Disconnect the AC power cord or DC power source and all external cables.
- Step 3** Attach the antistatic wrist strap to your wrist and connect its cord to the ESD socket on the top, left-hand side on the front of the appliance.
- Step 4** Remove the appliance cover. For instructions, see the [“Removing the Cover”](#) section on page 4-3.
- Step 5** Disconnect any cables attached to any adapter cards.
- Step 6** Remove the PCI riser assembly. For instructions, see the [“Removing the PCI Riser Assembly”](#) section on page 4-14. Then, turn the riser adapter card assembly upside down to remove the adapter card.
- Step 7** Remove the rear retention screw that fastens the adapter card to the rear bracket. (See location 1 or 4 in [Figure 4-8](#).)

Figure 4-8 Removing a Full-Height Adapter Card

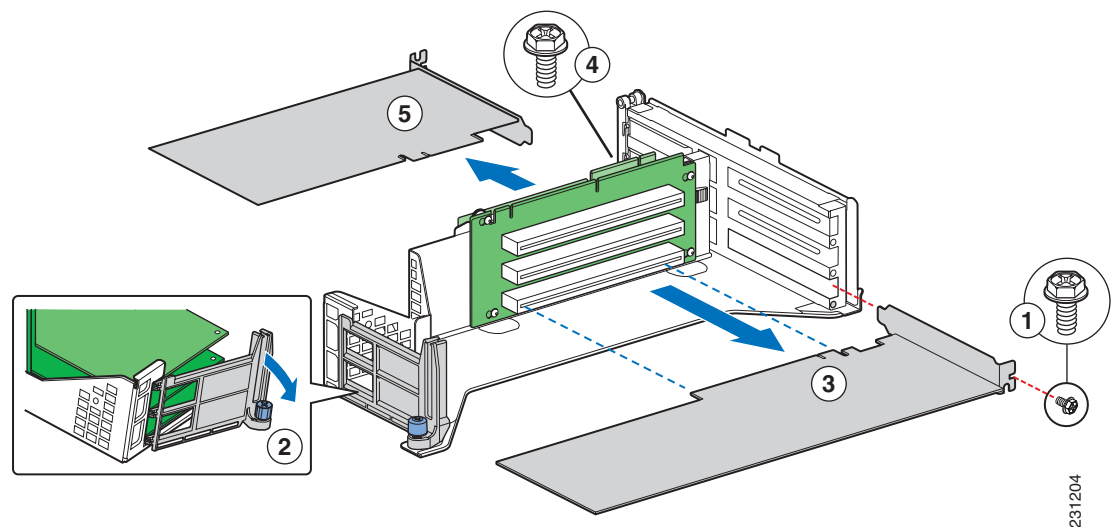

231204

1	Rear retention screw	4	Rear retention screw
2	Front retention clip	5	Adapter card
3	Adapter card		

- Step 8** When removing a full-height adapter card, remove the front retention clip by loosening the blue captive screw and rotating the clip outward. (See location 2 in [Figure 4-8 on page 4-15](#).)
- Step 9** Disengage the three plastic tabs from the metal sidewall.
- Step 10** Remove the adapter card from the PCI slot. (See item 3 or 5 in [Figure 4-8 on page 4-15](#)).

Installing a PCI Adapter Card

To install a PCI adapter card in the riser card assembly:

- Step 1** Review the information in the [“Safety Warnings” section on page x](#) and the [“Safety Guidelines” section on page 2-2](#).
- Step 2** Power down the appliance and all external devices. Disconnect the AC power cord or DC power source and all external cables.
- Step 3** Attach the antistatic wrist strap to your wrist and connect its cord to the ESD socket on the top, left-hand side on the front of the appliance.
- Step 4** Remove the appliance cover. For instructions, see the [“Removing the Cover” section on page 4-3](#).
- Step 5** Disconnect any cables attached to any adapter cards.
- Step 6** Remove the PCI riser assembly. For instructions, see the [“Removing the PCI Riser Assembly” section on page 4-14](#). Then, turn the riser adapter card assembly upside down to remove the adapter card.
- Step 7** If the adapter card slot was empty before installing the new card, remove the adapter card filler panel.
- Step 8** For a full-height adapter card, remove the front retention clip by loosening the blue captive thumbscrew and rotating the clip outward (see location 2 in [Figure 4-8 on page 4-15](#)). Then, disengage the three plastic tabs from the metal sidewall.
- Step 9** With the riser card assembly upside down, slide the adapter card onto the sheet metal and attach it to the appropriate riser card connector. Be sure that the adapter card edge connector is seated in the riser card connector correctly.
- Step 10** Fasten the adapter card to the riser card assembly bracket using the rear retention screw (see location 1 or 4 in [Figure 4-8 on page 4-15](#)) and, for full-height cards, by also replacing the front retention clip and tightening the captive thumbscrew. (See location 2 in [Figure 4-8 on page 4-15](#).)
- Step 11** Install the PCI riser assembly into the appliance. For instructions, see the [“Installing the PCI Riser Assembly” section on page 4-17](#) on this page.
- Step 12** Install the appliance cover. For instructions, see the [“Installing the Cover” section on page 4-20](#).
- Step 13** Plug all peripheral devices and the AC power cable or DC power source into the appliance.

Installing the PCI Riser Assembly

To install the PCI riser in the appliance:

-
- Step 1** Attach the riser card assembly to the appliance system board by grasping the two blue handles and inserting the two riser card edge connectors into the superslot header and the smaller low-profile riser card header next to it on the appliance system board. (See location 1 in [Figure 4-7 on page 4-14](#).)
 - Step 2** Align the forks on the riser card assembly with the pins on the rear chassis panel. (See location 2 in [Figure 4-7 on page 4-14](#).)
 - Step 3** If this is the last task you are performing, replace the processor air duct and the top cover of the chassis. For more information, see the [“Removing and Installing the Processor Air Duct” section on page 4-7](#) and the [“Installing the Cover” section on page 4-20](#).
 - Step 4** Reconnect all the external cables and plug in the AC power cord or DC power source.
-

Installing or Replacing a Power Supply

**Caution**

Your Cisco ADE 2130 and 2140 Series appliance does not have a redundant power supply unless you have purchased an optional second power supply. If there is no second power supply, before replacing an existing power supply, you must first take the appliance out of service. To do so, turn off all external devices connected to the appliance, turn off the appliance by pressing the power button, and unplug the AC power cord or DC power source.

**Caution**

If only one power supply is installed, it must be in the right-hand slot and a power supply blank filler panel must be installed in the left-hand slot to ensure proper cooling. (See location 5 in [Figure 1-5 on page 1-9](#).)

**Warning**

Never install an AC power module and a DC power module in the same chassis. Statement 1050

The Cisco ADE 2130 and 2140 Series appliance can be equipped with either AC or DC power supplies and you can operate the appliance with one or two of these power supplies installed. If you have two AC or DC power supplies, the power supplies create redundancy for the appliance, enabling one to become a backup for the other in case of failure.

Redundant power supplies also enable you to “hot-swap” a power supply, if you need to replace it. In other words, you can replace a power supply while the appliance is running. To maintain hot-swap capability, make sure that there is an active power supply in both appliance slots before replacing (hot-swapping) a power supply.

The AC or DC power supplies are accessible from the rear of the appliance (see locations 4 and 5, respectively, in [Figure 1-5 on page 1-9](#)). If the appliance is equipped with only one power supply, the space next the module is occupied with a blank filler panel.

**Note**

Figure 1-5 on page 1-9 shows two different power supplies (one AC and one DC) together in a Cisco ADE 2130 and 2140 Series appliance for illustration purposes, only. An actual configuration cannot combine two different power supplies; the appliance would include either two AC modules (or an AC module and a blank filler panel), or two DC modules (or a DC module and a blank filler panel).

This section includes the following topics

- [Replacing a Redundant Power Supply, page 4-18](#)
- [Replacing a Nonredundant Power Supply, page 4-19](#)
- [Adding a New Redundant Power Supply, page 4-19](#)

Replacing a Redundant Power Supply

If you have two power supplies (AC or DC) installed in your Cisco ADE 2130 and 2140 Series appliance, one of the modules is redundant, enabling you to hot-swap one of the power modules (replace a module without powering down the system), if you need to replace one of the power supplies.

To replace a redundant power supply:

- Step 1** Check the status LED on the power supplies (see location 2 in [Figure 4-9 on page 4-18](#)) to determine which power supply has failed.
- Step 2** Disconnect the appropriate AC or DC power source.

Figure 4-9 AC and DC Power Supply Modules

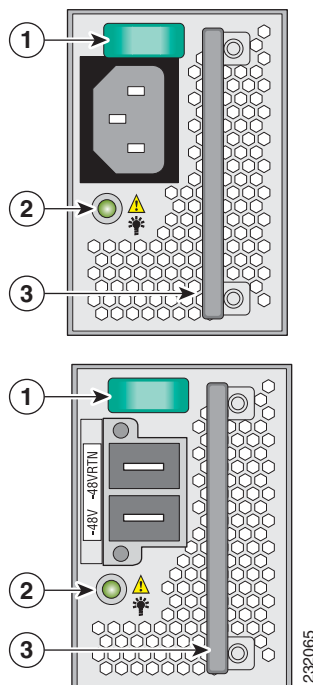

1	Safety lock (green)	3	Handle
2	Status LED		

- Step 3** Press and hold the green safety lock (see location 1 in [Figure 4-9](#)) downward to disengage the power supply.
- Step 4** Grasp the handle (see location 3 in [Figure 4-9](#)) and pull the power supply from the appliance chassis.
- Step 5** Slide the new power supply into the appliance chassis until it clicks into place.

Replacing a Nonredundant Power Supply

If your Cisco ADE 2130 and 2140 Series appliance has a single power supply (AC or DC), you can replace that power supply only when the appliance is safely powered down.

To replace a nonredundant power supply module:

- Step 1** Turn off all external devices connected to the appliance, turn off the appliance by pressing the power button, and unplug the appropriate AC or DC power source.
- Step 2** Press and hold the green safety lock (see location 1 in [Figure 4-9 on page 4-18](#)) downward to disengage the power supply.
- Step 3** Grasp the handle (see location 3 in [Figure 4-9 on page 4-18](#)) and pull the power supply from the appliance chassis.
- Step 4** Slide the new power supply into the appliance chassis until it clicks into place.

Adding a New Redundant Power Supply



Note

Add a redundant power supply module for the Cisco ADE 2130 and 2140 Series appliance must be of the same type (AC or DC) as the existing module.

To add an additional power supply module to an appliance that has a single power supply:

- Step 1** Remove the blank filler panel from the rear panel by pressing the two release tabs toward each other (see location 1 in [Figure 4-10](#)).
- Step 2** Pull the blank filler panel from the appliance chassis.

Figure 4-10 Blank Filler Panel and AC Power Module

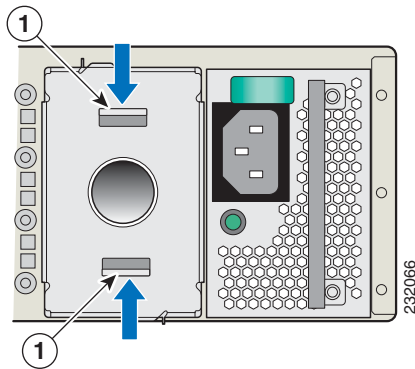

1	Release tabs
----------	--------------

Step 3 Slide the new power supply into the appliance chassis until it clicks into place.

Step 4 Save the blank filler panel, in case you need to use it at a later date.

**Note**

A blank filler panel is shown next to an AC power supply module (see [Figure 4-10](#)). The blank filler panel can also be used alongside a DC power module.

Completing the Installation

To complete your installation, you must reinstall the Cisco ADE 2130 and 2140 Series appliance cover and connect all external cables. Follow the instructions in this section.

**Caution**

To maintain proper cooling and airflow, install the appliance cover before turning on the appliance. Operating the appliance for extended periods (over 30 minutes) with the appliance cover removed might damage the appliance components.

**Warning**

The covers are an integral part of the safety design of the product. Do not operate the unit without the covers installed. Statement 1077

Installing the Cover

To install the appliance cover after you have completed your hardware options installation or maintenance:

Step 1 Review the information in the “[Safety Warnings](#)” section on page x and the “[Safety Guidelines](#)” section on page 2-2.

- Step 2** Place the cover over the appliance so that the side edges of the cover sit just inside the appliance sidewalls. (See location 1 in [Figure 4-11](#).)
- At the front of the cover, you should see a small gap (approximately 1/8-inch [3-mm]) between the appliance chassis cover and the front of the appliance.

Figure 4-11 Installing the Cisco ADE 2130 and 2140 Series Appliance Cover

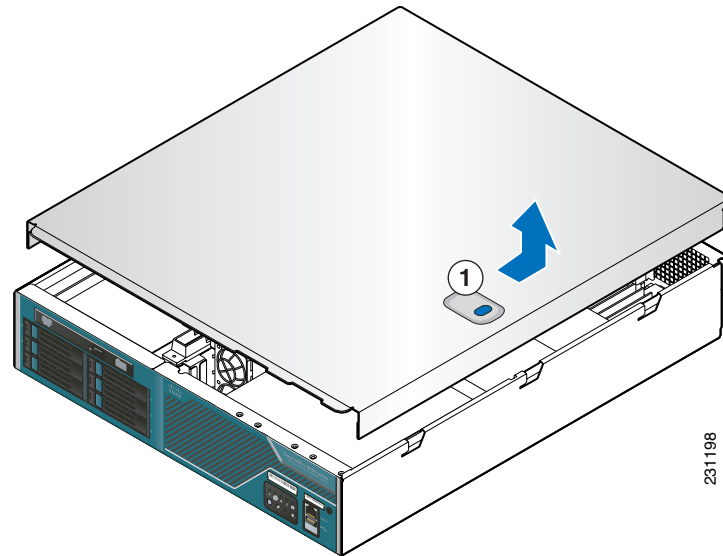

1	Blue button
----------	-------------

- Step 3** Press down slightly on the appliance cover behind the edge and slide the cover forward until it clicks into place.
- Step 4** Reconnect all external cables and the AC power cord or DC power source.



APPENDIX **A**

Troubleshooting

The Cisco ADE 2130 and 2140 Series appliance undergoes extensive testing before it leaves the factory. If you encounter problems, use the information in this appendix to help isolate problems or to eliminate the appliance as the source of the problem.

Although an overtemperature or overvoltage condition is unlikely at initial startup, a discussion of environmental temperature and voltage monitoring functions is provided in the [“Environmental Monitoring” section on page 1-16](#).



Note

The procedures in this chapter assume that you are troubleshooting the initial Cisco ADE 2130 and 2140 Series appliance startup, and that the appliance is in the original factory configuration. If you have removed or replaced components or changed any default settings, the recommendations in this chapter might not apply.

This appendix does not cover every possible trouble event that might occur on an appliance but instead focuses on those events that are frequently seen by the customer.

This appendix contains the following sections:

- [Troubleshooting Overview, page A-1](#)
- [Problem Solving, page A-2](#)
- [Reading the LEDs, page A-5](#)
- [Product Serial Number Location, page A-7](#)

Troubleshooting Overview

Before and at initial system boot, you should verify the following:

- External power cable is connected, and the proper power source is being applied. (See the [“Power Considerations” section on page 2-10](#), the [“Powering Up the Cisco ADE 2130 and 2140 Series Appliance” section on page 3-20](#), and the [“Troubleshooting the Power and Cooling Systems” section on page A-3](#).)
- The appliance fan and blower are operating. (See the [“Airflow Guidelines” section on page 2-9](#) and the [“Troubleshooting the Power and Cooling Systems” section on page A-3](#)).
- The appliance software boots successfully.
- The adapter cards (if installed) are properly installed in their slots, and each initializes (is enabled by the appliance software) without problems.

When each of these conditions is met, the hardware installation is complete, and you should proceed to perform a basic configuration (see the software installation guide or user guide that shipped with your appliance for proper configuration procedures).

If you cannot locate the source of the problem, contact a customer service representative for information on how to proceed. For technical support information, see the *Cisco Information Packet* publication that shipped with your appliance. Before you call, have the following information ready:

- Appliance chassis type and serial number (see the “[Cisco Product Identification Tool](#)” section on page 1-4 or the “[Cisco Product Identification Tool](#)” section on page A-7 for more information)
- Maintenance agreement or warranty information (see the *Cisco Information Packet*)
- Type of software and version number (if applicable)
- Date you received the new appliance
- Brief description of the problem you are having and the steps you have taken to isolate and resolve the problem

**Note**

Ensure you provide the customer service representative with any upgrade or maintenance information that was performed on the Cisco ADE 2130 and 2140 Series appliance after your initial installation. (See the “[Creating a Site Log](#)” section on page 2-15 and [Appendix B, “Site Log,”](#) for Site Log information.)

Problem Solving

The key to problem solving is to isolate the problem to a specific location by comparing what the Cisco ADE 2130 and 2140 Series appliance is doing to what it should be doing.

In other words, when troubleshooting, define the specific symptoms, identify all potential problems that could be causing the symptoms, and then systematically eliminate each potential problem (from most likely to least likely) until the symptoms disappear.

The following steps provide guidelines to use in the problem-solving process:

-
- Step 1** Analyze the problem and create a clear problem statement. Define symptoms and potential causes.
 - Step 2** Gather the facts that you need to help isolate possible causes.
 - Step 3** Consider possible causes based on the facts that you gathered.
 - Step 4** Create an action plan based on those causes. Begin with the most likely problem and devise a plan in which you manipulate only one variable.
 - Step 5** Implement the action plan. Perform each step carefully while testing to see whether the symptom disappears.
 - Step 6** Analyze the results to determine whether the problem has been resolved. If the problem was resolved, consider the process complete.
 - Step 7** If the problem has not been resolved, create an action plan based on the next most probable cause on your list. Return to [Step 4](#) and repeat the process until the problem is solved.
 - Step 8** Make sure that you undo anything that you changed while implementing your action plan. Remember that you want to change only one variable at a time.
-

**Note**

The LEDs on the front panel of the appliance enable you to determine appliance performance and operation. For a description of these LEDs, see the [“Reading the LEDs” section on page A-5](#).

When problem solving, check the following appliance subsystems first:

- Power and cooling systems—External power source, AC power cable or DC power wires, and appliance fans. Also check for inadequate ventilation, air circulation, or environmental conditions.
- Adapter cards—Checking the LEDs on the adapter card can help you to identify a failure.
- Cables—Ensure that the external cables connecting the appliance to the network are all secure.

Troubleshooting the Power and Cooling Systems

Both the power LED and the fans can help you troubleshoot a power problem. Check the following items to help isolate the problem:

- When the Cisco ADE 2130 and 2140 Series appliance is connected to the power source, is the appliance power LED on the front panel on?
 - If not, check the connection of the AC power cord or DC power wires.
 - If the power LED is still off, the problem might be a power supply failure.
- Does the appliance shut down after being on for only a short time?
 - Check for an environmentally induced shutdown (see the [“Environmental Reporting Features” section on this page](#)).
 - Check the fans. If the fans are not working, the appliance will overheat and shut itself down.
 - If the fans are not working, you might need to check the power supply connections to the fans. Checking this connection will require you to shut down the appliance, remove any external cables, and open up the appliance. For more information, see the [“Removing the Cover” section on page 4-3](#).
 - Ensure that the appliance intake and exhaust vents are clear.
 - Check the environmental site requirements in the [“Temperature and Humidity Guidelines” section on page 2-9](#).
- Does the appliance partially boot, but the LEDs do not light?
 - Check for a power supply failure by inspecting the power LED on the front panel of the appliance. If the LED is on, the power supply is functional.
 - If the LED is off, refer to the *Cisco Information Packet* for warranty information or contact your customer service representative.

Environmental Reporting Features

The Cisco ADE 2130 and 2140 Series appliance has protection circuits that monitor and detect overcurrent, overvoltage, and overtemperature conditions inside the appliance. If the power supply shuts down or latches off, an AC cycle of off for 15 seconds and on for 1 second resets the power supply. For more information, see the [“Environmental Monitoring” section on page 1-16](#).

The following conditions can cause an abnormally high appliance temperature:

- Fan failure
- Air conditioner failure in the room
- Airflow blocked to cooling vents

Take steps to correct the problem. For information about environmental operating conditions, see the [“Temperature and Humidity Guidelines”](#) section on page 2-9.

Troubleshooting Adapter Cards, Cables, and Connections

Network problems can be caused by an adapter card, cables or cable connections, or external devices such as a hub, wall jack, WAN interface, or terminal. Check for the following symptoms to help isolate the problem:

- Adapter card is not recognized by the Cisco ADE 2130 and 2140 Series appliance.
 - Make sure that the adapter card is firmly seated in its slot. For information on adapter card installation and removal, see the [“Completing the Installation”](#) section on page 4-20.
 - Check the LEDs on the adapter card. Each adapter card has its own set of LEDs. For information on these LEDs, see the [“Reading the LEDs”](#) section on page A-5.
 - Make sure that you have a version of software that supports the adapter card. Refer to the documentation that was included with your adapter card.
- Adapter card is recognized, but interface ports do not initialize.
 - Make sure that the adapter card is firmly seated in its slot. For information on adapter card installation and removal, see the [“Completing the Installation”](#) section on page 4-20.
 - Check external cable connections.
 - Make sure that you have a version of software that supports the adapter card. Refer to the documentation that was included with your adapter card.
- The Cisco ADE 2130 and 2140 Series appliance does not boot properly, or it constantly or intermittently reboots.
 - Make sure that the adapter card is firmly seated in its slot. For information on adapter card installation and removal, see the [“Completing the Installation”](#) section on page 4-20.
 - Check the appliance chassis or the application software. For warranty information, refer to the *Cisco Information Packet* publication that shipped with your appliance or contact your customer service representative.
- If you are using the console port with a terminal, and the Cisco ADE 2130 and 2140 Series appliance boots but the console screen is frozen.
 - Check the external console connection.
 - Verify that the parameters for your terminal are set as follows:
 - (a) The terminal should have the same data rate that the appliance has (9600 bps is the default).
 - (b) 8 data bits.
 - (c) No parity generated or checked.
 - (d) 1 stop bit.
- The Cisco ADE 2130 and 2140 Series appliance powers up and boots only when an adapter card is removed.

- Check the adapter card. There might be a problem with the adapter card. Refer to the documentation that was included with your adapter card.
- For warranty information, refer to the *Cisco Information Packet* publication that shipped with your appliance or contact your customer service representative.
- The Cisco ADE 2130 and 2140 Series appliance powers up and boots only when a particular cable is disconnected.
 - There might be a problem with the cable. For warranty information, refer to the *Cisco Information Packet* publication that shipped with your appliance or contact your customer service representative.

Reading the LEDs

There are several LEDs on the Cisco ADE 2130 and 2140 Series appliance. LEDs serve the following purposes:

- Indicate that basic power is available to the appliance
- Guide you to a broken adapter card, or to one that has failed its diagnostics
- Give an indication that traffic is flowing through the adapter card to the appliance

The LEDs on the front panel of the Cisco ADE 2130 and 2140 appliance and corresponding adapter card are aids for determining appliance and adapter performance and operation.

Front-Panel LEDs

Figure A-1 shows the locations of the appliance's front-panel LEDs. Table A-1 describes these LEDs.

Figure A-1 Front-Panel LEDs

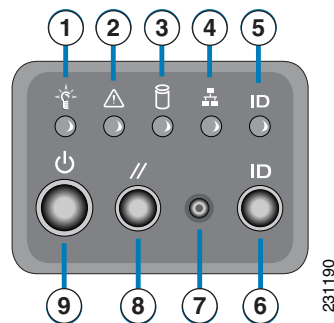

Table A-1 Front-Panel LEDs

LED	Color	State	Description
Appliance Power (location 1)	Green	On	Power on
	Off	Off	Power off

Table A-1 Front-Panel LEDs (continued)

LED	Color	State	Description
Appliance Status (location 2)	Green	On	Standby or ready for operation
	Green	Blinking	Degraded operation (for example, power supply nonredundancy, part of system memory mapped out of BIOS)
	Amber	On	One or more critical fault conditions
	Amber	Blinking	One or more noncritical fault conditions
Hard Disk Drive (location 3)	Green	On	HDD activity
	Amber	On	HDD fault Note This is an aggregated indication for all hard disk drives. Each hard disk drive contains its own activity and fault LEDs.
NICs (location 4)	Green	On	NIC activity
System ID (location 5)	Blue		System identity Note LED can be toggled remotely or by the front-panel ID switch to obtain the system's identity.

NIC LEDs

Figure A-2 shows the NIC 1 and NIC 2 LEDs located on the rear of the appliance. These LEDs indicate the connection activity and speed of the NIC ports. Table A-2 on page A-7 describes the activity and connection speed associated with each LED state.

Figure A-2 NIC 1 and NIC 2 LEDs

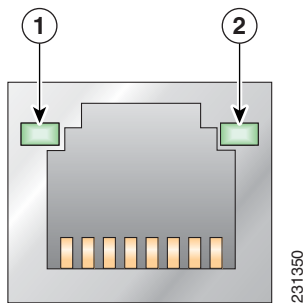
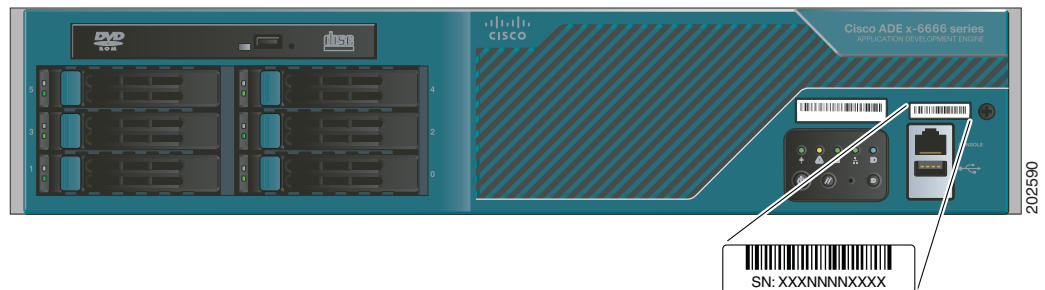

Table A-2 NIC 1 and NIC 2 LED Descriptions

LED	Color	State	Description
Left (location 1)		Off	10-Mb/s connection
	Green	Solid	100-Mb/s connection
	Amber	Solid	1000-Mb/s (or 1-Gb/s) connection
Right (location 2)		Off	No network connection
	Green	Solid	Network connection
	Green	Blinking	Transmit/receive activity

Product Serial Number Location

On the Cisco ADE 2130 and 2140 Series appliance, the serial number label is located on the right-hand corner above the RJ-45 serial connector on the front of the appliance. (See [Figure A-3](#).)

Figure A-3 Cisco ADE 2130 and 2140 Series Appliance Serial Number Location**Note**

The serial number for the Cisco ADE 2130 and 2140 Series appliance is 11 characters long.

Cisco Product Identification Tool

The Cisco Product Identification (CPI) tool helps you retrieve the serial number of your Cisco products.

Before you submit a request for service online or by phone, use the CPI tool to locate your product serial number. You can access this tool from the Cisco Support website by clicking the **Get Tools & Resources** link, clicking the **All Tools (A-Z)** tab, and then choosing **Cisco Product Identification Tool** from the alphabetical list.

This tool offers three search options:

- Search by product ID or model name
- Browse for Cisco model
- Copy and paste the output of the **show** command to identify the product

Search results show an illustration of your product with the serial number label location highlighted. Locate the serial number label on your product and record the information before you place a service call.

The CPI tool is accessed via Cisco.com at the following URL:

<http://tools.cisco.com/Support/CPI/index.do>

Access to the CPI tool on the Cisco Support website requires a Cisco.com user ID and password. If you have a valid service contract but do not have a user ID or password, you can register at:

<http://tools.cisco.com/RPF/register/register.do>



APPENDIX **B**

Site Log

The Site Log provides a record of all actions related to installing and maintaining the Cisco ADE 2130 and 2140 Series appliance. Keep the log in an accessible place near the appliance chassis so that anyone who performs tasks has access to it. Use the Installation Checklist (see the [“Installation Checklist” section on page 2-15](#)) to verify the steps in the installation and maintenance of your appliance.

Site Log entries might include the following:

- Installation progress—Make a copy of the appliance Installation Checklist, and insert it into the Site Log. Make entries as you complete each task.
- Upgrade, removal, and maintenance procedures—Use the Site Log as a record of ongoing appliance maintenance and expansion history. Each time a task is performed on the appliance, update the Site Log to reflect the following:
 - Configuration changes
 - Maintenance schedules and requirements
 - Maintenance procedures performed
 - Intermittent problems
 - Comments and notes

[Table B-1 on page B-2](#) shows a sample site log. Make copies of the sample or design your own site log to meet the needs of your site and equipment.



APPENDIX **C**

Maintaining the Cisco ADE 2130 and 2140 Appliance

Your Cisco ADE 2130 and 2140 Series appliance is configured to your order and is ready for installation and startup when it leaves the factory. After you install and configure your appliance, you might have to perform specific maintenance procedures and operations to ensure that the appliance is operating properly.

Following these preventive maintenance procedures can keep your appliance in top operating condition and minimize the need for costly, time-consuming service procedures.



Caution

To help prevent problems, before performing any procedures in this chapter, review the [“Safety Warnings”](#) section on page x and the [“Safety Guidelines”](#) section on page 2-2.

The following sections discuss various environmental factors that can adversely affect appliance performance and longevity.

Maintaining Your Site Environment

Good preventive maintenance includes regular visual inspections of the appliance including exterior cleaning and inspection.

Other important areas are:

- [General Exterior Cleaning and Inspection, page C-2](#)
- [Cooling, page C-3](#)
- [Temperature, page C-3](#)
- [Humidity, page C-4](#)
- [Altitude, page C-4](#)
- [Electrostatic Discharge, page C-4](#)
- [Electromagnetic and Radio Frequency Interference, page C-4](#)
- [Magnetism, page C-5](#)
- [Power Source Interruptions, page C-5](#)

General Exterior Cleaning and Inspection

This section details the cleaning requirements for exterior surfaces of the appliance and the inspection of cables and adapter cards.

**Caution**

Never spray cleaning solution on the surfaces of the appliance. Overspray can penetrate into the appliance and cause electrical problems and corrosion.

Appliance

Use a lint-free, nonabrasive cloth to perform cleaning. *Do not* use a solvent, abrasive cleaning agents, or tissue paper. If the appliance is dirty (for example, with thick dust), use a soft damp cloth and wipe the surface of the appliance gently.

Immediately wipe off any water or liquid from the appliance.

Dust and Particles

A clean operating environment can greatly reduce the negative effects of dust and other particles, which act as insulators and interfere with the operation of an appliance's mechanical components. In addition to regular cleaning, you should follow these guidelines to deter contamination of the appliance:

- Do not permit smoking anywhere near the appliance.
- Do not permit food or drink near the appliance.

Cables and Connectors

Inspect cables and connectors to and from your appliance periodically to see if they are worn out or loose.

Adapter Cards

Check the connections on the adapter cards. Be sure they are secured to the appliance and have not been jarred loose or mechanically damaged.

Corrosion

The oil from a person's fingers or prolonged exposure to high temperature or humidity can corrode the gold-plated edge connectors and pin connectors on adapter cards in the appliance. This corrosion on adapter card connectors is a gradual process that can eventually lead to intermittent failures of electrical circuits.

To prevent corrosion, you should avoid touching contacts on adapter cards. Protecting the appliance from corrosive elements is especially important in moist and salty environments, which tend to promote corrosion. Also, as a further deterrent to corrosion, the appliance should not be used in extreme temperatures, as explained in the [“Temperature” section on page C-3](#).

Cooling



Warning

Blank faceplates and cover panels serve three important functions: they prevent exposure to hazardous voltages and currents inside the chassis; they contain electromagnetic interference (EMI) that might disrupt other equipment; and they direct the flow of cooling air through the chassis. Do not operate the system unless all cards, faceplates, front covers, and rear covers are in place.

Statement 1029

Exhaust fans in the power supply and in the appliance itself cool the power supply and the appliance by drawing air in through various openings in the front of the appliance and blowing it out the back. However, the fans also draw dust and other particles into the appliance, causing contaminant buildup, which results in an increase in the appliance's internal temperature and interferes with the operation of various appliance components.

To avoid these conditions, we recommend keeping your work environment clean to reduce the amount of dust and dirt around the appliance, thereby reducing the amount of contaminants drawn into the appliance by the fans.

Temperature

Temperature extremes can cause a variety of problems, including premature aging and failure of chips or mechanical failure of devices. Extreme temperature fluctuations can cause chips to become loose in their sockets and can cause expansion and contraction of disk drive platters, resulting in read or write data errors.

To minimize the negative effects of temperature on appliance performance, follow these guidelines:

- Ensure that the appliance is operated in an environment no colder than 50°F (10°C) or hotter than 95°F (35°C).
- Ensure that the appliance has adequate ventilation. Do not place it within a closed-in wall unit or on top of cloth, which can act as insulation. Do not place it where it will receive direct sunlight, particularly in the afternoon. Do not place it next to a heat source of any kind, including heating vents during winter.

Adequate ventilation is particularly important at high altitudes. Appliance performance may not be optimum when the appliance is operating at high temperatures as well as high altitudes.

- Make sure that all slots and openings on the appliance remain unobstructed, especially the fan vents on the back of the appliance.
- Clean the appliance at regular intervals to avoid any buildup of dust and debris, which can cause an appliance to overheat.
- If the appliance has been exposed to abnormally cold temperatures, allow a 2-hour warm-up period to bring it up to normal operating temperature before turning it on. Failure to do so may cause damage to internal components, particularly the hard disk drive.

Humidity

High-humidity conditions can cause moisture migration and penetration into the appliance. This moisture can cause corrosion of internal components and degradation of properties, such as electrical resistance, thermal conductivity, physical strength, and size. Extreme moisture buildup inside the appliance can result in electrical shorts, which can cause serious damage to the appliance.

Each appliance is rated to operate at 8 to 80 percent relative humidity, with a humidity gradation of 10 percent per hour. Buildings in which climate is controlled by air conditioning in the warmer months and by heat during the colder months usually maintain an acceptable level of humidity for appliances. However, if an appliance is located in an unusually humid location, a dehumidifier can be used to maintain the humidity within an acceptable range.

Altitude

Operating an appliance at high altitude (low pressure) reduces the efficiency of forced, convection cooling and can result in electrical problems related to arcing and corona effects. This condition can also cause sealed components with internal pressure, such as electrolytic capacitors, to fail or perform at reduced efficiency.

Electrostatic Discharge

Electrostatic discharge (ESD) results from the buildup of static electricity on the human body and certain other objects. This static electricity is often produced by simple movements, such as walking across a carpet. ESD is a discharge of a static electrical charge that occurs when a person whose body contains such a charge touches a component in the appliance. This static discharge can cause components, especially chips, to fail. ESD is a problem particularly in dry environments where the relative humidity is below 50 percent.

To reduce the effects of ESD, you should observe the following guidelines:

- Wear a grounding wrist strap. If a grounding wrist strap is unavailable, touch an unpainted metal surface on the appliance chassis periodically to neutralize any static charge.
- Keep components in their antistatic packaging until they are installed.
- Avoid wearing clothing made of wool or synthetic materials.

Electromagnetic and Radio Frequency Interference



Warning

Blank faceplates and cover panels serve three important functions: they prevent exposure to hazardous voltages and currents inside the chassis; they contain electromagnetic interference (EMI) that might disrupt other equipment; and they direct the flow of cooling air through the chassis. Do not operate the system unless all cards, faceplates, front covers, and rear covers are in place.

Statement 1029

Electromagnetic interference (EMI) and radio frequency interference (RFI) from an appliance can adversely affect devices, such as radio and television (TV) receivers operating near the appliance. Radio frequencies emanating from an appliance can also interfere with cordless and low-power telephones.

RFI is defined as any EMI with a frequency above 10 kilohertz (kHz). This type of interference can travel from the appliance to other devices through the power cable and power source or through the air like transmitted radio waves. The Federal Communications Commission (FCC) publishes specific regulations to limit the amount of EMI and RFI emitted by computing equipment. Each appliance meets these FCC regulations.

To reduce the possibility of EMI and RFI, follow these guidelines:

- Operate the appliance only with the appliance cover installed.
- Ensure that the screws on all peripheral cable connectors are securely fastened to their corresponding connectors on the back of the appliance.

Magnetism

Because they store data magnetically, hard disk drives are susceptible to the effects of magnetism. Hard disk drives should never be stored near magnetic sources such as the following:

- Monitors
- Printers
- Telephones with real bells
- Fluorescent lights

Power Source Interruptions

Appliances are especially sensitive to variations in voltage supplied by the AC power source. Overvoltage, undervoltage, and transients (or spikes) can erase data from the memory or even cause components to fail. To protect against these types of problems, power cables should always be properly grounded and one or both of the following methods should be used:

- Place the appliance on a dedicated power circuit (rather than sharing a circuit with other electrical equipment). In general, do not allow the appliance to share a circuit with any of the following:
 - Copier machines
 - Teletype machines
 - Laser printers
 - Facsimile machines
 - Any other motorized equipment

Besides the above equipment, the greatest threats to an appliance's supply of power are surges or blackouts caused by electrical storms.

If a blackout occurs—even a temporary one—while the appliance is turned on, turn off the appliance immediately and disconnect it from the electrical outlet. Leaving the appliance on may cause problems when the power is restored.



INDEX

Numerics

- 2-post hardware kit
 - rack-mount [3-4](#)
- 2-post rack, mid-mounting appliance on [3-5](#)
- 4-post hardware kit
 - rack-mount [3-7](#)
- 4-post rack, mounting appliance on [3-7](#)

A

- AC power up
 - procedure [3-20](#)
- adapter cards
 - troubleshooting [A-4](#)
- adapter pinouts [1-14](#)
- ADE 2130 and 2140 Series appliance
 - front view [1-6](#)
 - rear view [1-8](#)
- ADE 2130 Series appliance
 - configuration [1-4](#)
- ADE 2140 Series appliance
 - configuration [1-5](#)
- air duct, processor
 - removing [4-7](#)
- airflow
 - guidelines [2-9](#)
- altitude
 - guidelines [C-4](#)
- appliance cover
 - installing [4-20](#)
 - removing [4-3](#)
- auxiliary port

pinouts [1-14](#)

B

- back panel [1-9, 3-15, 3-17](#)
- blank (power supply) filler panel, removing [4-20](#)

C

- cable
 - management [3-19](#)
- checking
 - LEDs [3-21](#)
- checklist, installation [2-15](#)
- configuration
 - ADE 2130 Series appliance [1-4](#)
 - ADE 2140 Series appliance [1-5](#)
 - site [2-8](#)
- connecting
 - network and console cables [3-18](#)
 - network interface [3-18](#)
- connections
 - console port [2-16](#)
 - Ethernet [2-16](#)
 - troubleshooting [A-4](#)
- considerations
 - power [2-10](#)
- console port
 - connections [2-16](#)
 - pinouts
 - serial [1-13](#)
 - serial [1-12](#)
 - console port signaling cabling, DB-9 (table) [1-14](#)

cooling system
 troubleshooting [A-3](#)
 corrosion
 preventing damage [C-2](#)
 CPI tool
 identification [1-4, A-7](#)

D

DC power up
 procedure [3-21](#)
 DIMMs
 installing [4-11](#)
 removing [4-12](#)
 dust
 preventing damage [C-4](#)

E

electricity
 safety with [2-3](#)
 electromagnetic interference
 See EMI
 electrostatic discharge
 See ESD
 EMI
 preventing effects of [C-4](#)
 environment
 maintaining [C-1](#)
 site [2-8](#)
 environmental
 features [A-3](#)
 specifications (table) [2-10](#)
 equipment
 racks
 rack-mounting [2-9](#)
 safety with [2-3](#)
 ESD

preventing damage [2-5, C-4](#)
 preventing effects of [C-4](#)

Ethernet
 connections [2-16](#)
 Ethernet ports
 NIC [1-11](#)

F

features
 environmental reporting [A-3](#)
 front panel
 LEDs and switches [1-7](#)
 front view
 ADE 2130 and 2140 Series appliance [1-6](#)

G

general
 precautions [2-2](#)
 guidelines
 airflow [2-9](#)
 lifting [2-6](#)
 rack installation [2-7](#)
 rack-mounting configuration [3-2](#)
 safety [2-2](#)
 temperature and humidity [2-9](#)
 temperature maintenance [C-3](#)

H

hardware
 installing [3-1](#)
 options [4-2](#)
 troubleshooting procedures [A-1](#)
 hardware options (table) [4-2](#)
 humidity
 maintenance guidelines [C-4](#)

I

identification

CPI [1-4, A-7](#)

information

packet [2-13](#)

installation

checklist [2-15](#)hardware [3-1](#)**K**

kit

2-post rack-mount (table) [3-4](#)4-post rack-mount (table) [3-8](#)**L**

LEDs

checking [3-21](#)front panel [1-7](#)front panel and NIC [A-5](#)NIC [1-9](#)power supply [1-10](#)lifting guidelines [2-6](#)

location

serial number [1-3, A-7](#)log, site [2-15, B-1](#)**M**

magnetism

preventing effects of [C-5](#)maintenance [C-1](#)temperature [C-3](#)

management

cable [3-19](#)

memory

installing [4-11](#)removing [4-12](#)

method of procedures

See MOPMOP [2-6, 2-11](#)**N**

network and console cables

connecting [3-18](#)

network interface

connecting [3-18](#)

NIC

Ethernet ports [1-11](#)LEDs [1-9](#)RJ-45 pinout [1-12](#)**O**

options

hardware [4-2](#)

overcurrent

protection [1-16](#)

overtemperature

protection [1-16](#)

overview

product [1-2](#)

overvoltage

protection [1-16](#)**P**

packet

information [2-13](#)packing list (table) [2-12](#)

PCI adapter card

installing [4-16](#)removing [4-15](#)

PCI riser card assembly

installing [4-17](#)removing [4-14](#)PCI-X and PCIe slots [4-13](#)

planning

site [2-6](#)

power

considerations [2-10](#)

power source interruptions

preventing damage from [C-5](#)

power supply

about [4-17](#)description [1-15](#)LEDs [1-10](#)redundant, adding new [4-19](#)replacing nonredundant [4-19](#)replacing redundant [4-18](#)

power system

troubleshooting [A-3](#)

precautions

general [2-2](#)

preventing

electrostatic discharge damage [2-5](#)

problem solving

See troubleshooting

procedure

AC power up [3-20](#)DC power up [3-21](#)method of [2-11](#)

processor air duct

removing [4-7](#)

product

overview [1-2](#)

product number

CADE-2130-K9, model

ADE 2130 [1-2](#)

CADE-2140-K9, model

ADE 2140 [1-2](#)

protection

overcurrent [1-16](#)overtemperature [1-16](#)overvoltage [1-16](#)

R

rack

2-post (telco) [2-8](#)4-post (open) [2-7](#)enclosed (do not use) [2-7](#)rack, mid-mounting on 2-post [3-5](#)rack, mounting on 4-post [3-7](#)

rack installation

guidelines [2-7](#)

rack-mount

2-post hardware kit [3-4](#)4-post hardware kit [3-7](#)

rack-mounting configuration

guidelines [3-2](#)radio frequency interference. *See* RFI

rear view

ADE 2130 and 2140 Series appliance [1-8](#)redundant power supply, replacing [4-18](#)

regulatory compliance

safety

information [1-16](#)

removing

ADE 1010 and 2120 Series appliance [3-22](#)appliance cover [4-3](#)

RFI

preventing effects of [C-4](#)

RJ-45 pinout

NIC [1-12](#)

S

safety

guidelines [2-2](#)

- information
 - regulatory compliance [1-16](#)
- serial
 - console port [1-12](#)
 - pinouts [1-13](#)
- serial number
 - location [1-3, A-7](#)
- shipment
 - unpacking and checking [2-12](#)
- site
 - configuration [2-8](#)
 - environment [2-8](#)
 - maintenance factors [C-1](#)
 - log [2-15, B-1](#)
 - planning [2-6](#)
 - requirement, MOPs [2-11](#)

W

- warranty [2-13](#)

T

- temperature
 - maintenance guidelines [C-3](#)
- temperature and humidity
 - guidelines [2-9](#)
- tools and equipment
 - for option installation [4-3](#)
 - required [2-14](#)
- troubleshooting
 - adapter cards [A-4](#)
 - cables [A-4](#)
 - connections [A-4](#)
 - cooling system [A-3](#)
 - front-panel and NIC LEDs [A-5](#)
 - power system [A-3](#)

U

- unpacking and checking
 - shipment [2-12](#)

